

Determination of blood glucose concentration by back propagation neural network

V. Ashok¹, S. Rajan Singh² and A. Nirmalkumar³

^{1,2}Dept. of BioMedical Engineering, Velalar College of Engineering, Erode-638009, India

³Dept. of Electrical and Electronic Engineering, Info Institute of Engineering, Coimbatore 641107, India
ashokvajravelu@gmail.com

Abstract

. This paper presents a supervised backpropagation neural (BPN) network for the determination of blood glucose in diabetic patients. Non- invasive measurement of blood glucose concentration based on reflected laser beam from the index finger has been reported in this paper. This method depends on Helium-Neon (He-Ne) gas laser operating at 632.8 nm wave length. During measurement the index finger is placed in the laser beam transceiver unit, the reflected optical signal is converted into its corresponding electrical signal and the obtained signal is processed by the neural network which presents the results in the form of blood glucose concentration. Diabetes database used for empirical comparisons and the results are shown that BPN network performs better.

Keywords: Artificial neural network, diabetes mellitus, non-invasive measurement, supervised learning.

Introduction

Diabetes mellitus has probably been known to medical science longer than any other hereditary metabolic disease. Twenty years ago, diabetes was considered as an uncommon disease with an adult prevalence of 1.3%. The latest WHO estimate is 220 million people worldwide and it can be doubled by the year 2030. It is a chronic, deliberating and costly disease causing severe complications including blindness, cardiac and kidney failure. Back propagation network (BPN) models are the popular network architecture used in the most of the research applications in medicine, engineering and mathematical modeling (Rumelhart *et al.*, 1986).

A constitutional disorder of carbohydrate metabolism characterized by inadequate secretion or utilization of insulin, by excessive urine production, by excessive amount of sugar in the blood and urine and by thirst, hunger and loss of weight. Basal insulin secretion is maintained at normal or reduced levels, but insulin release to a glucose load is delayed or reduced. It is often accompanied by disease of blood vessels, leading to premature atherosclerosis with myocardial infraction or stroke syndrome. Thus, alterations in blood vessel changes are quite evident at the stage of impaired glucose tolerance.

The indigenous developed non-invasive glucose monitor, which process optical signals of transmitted through or reflected by the stratum corneum, dermis and epidermis layers, subcutaneous tissue, interstitial fluid and blood vessels in both the arterial and venous blood, which represent independent compartments. We approach the problem by means of following steps: (a). Collecting non-invasive signals from non diabetic individuals and diabetic patients, (b). Simultaneously measuring blood glucose concentrations by an invasive

method and (c). Computing the values based on the correlation between measured blood glucose values and non-invasive optical signals (Ashok, 2010a). The signal related filter operation which ties to multiresolution analysis that we will look at Haar wavelet transform signal is used for to divide the original signal without any alterations as input to the BPN (Ashok, 2010b).

Neural network with its structure for diagnosing the Diabetes mellitus

From blood flow speed we can compute various associated parameters viz. blood pressure, blood protein, blood cholesterol and blood glucose. Artificial neural network with back propagation technique which is having the capability of continuous learning governs the blood flow and gives output with respect to standard blood composition (RBC, WBC, platelets, blood cholesterol & protein). Following the results of the experiment it can be stated that any alteration in the blood glucose level may results in the alteration of blood flow is indirectly proportional to the blood glucose level. Artificial neural network with back propagation technique which is having the capability of continuous leaving governs the flood flow and gives the output with respect to standard blood flow rate. The three layer neural network for non-invasive blood glucose diagnosis structure is shown in the Fig. 1.

Here, X_{i1} and X_{i2} are the two inputs from the output of Fast Haar wavelet analysis bank as approximated and detailed signals. The I_{i1} and I_{i2} are the two input neurons in the input layer, H_1 and H_2 are the two hidden neurons in the hidden layer and finally O_1 is the output neuron in the output layer. Y_o is the output which gives the blood glucose value in mg/dl. The V_{i11} , V_{i12} and V_{i21} , V_{i22} are the weights of the arms from input neuron to hidden neuron and W_{o1} , W_{o2} are the weights of the arms from

hidden neurons to output neuron. The target value of the output neuron is fixed accordingly to the mean value of the input signals.

Fig. 1. Three layer neural networks for non-invasive blood glucose diagnosis structure

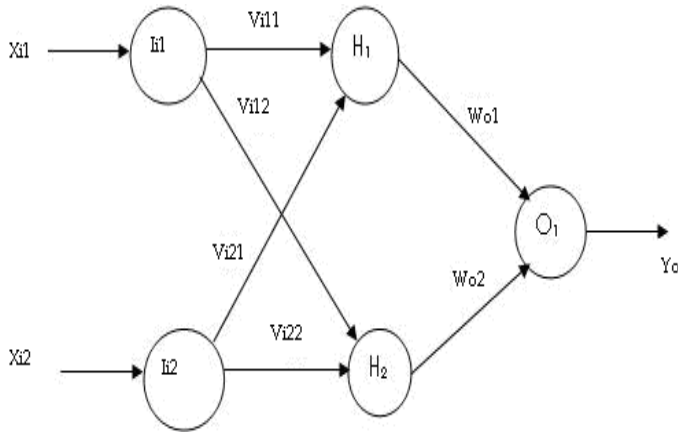

Formulation of network models for diabetes data

Data collected from 700 individuals (400 diabetic & 300 non-diabetic) attending a private hospital during the period 2007-2009 were used in this work for empirical comparison of the proposed models. The WHO criteria for classifying a patient as in normal condition namely fasting blood glucose minimum as 70 mg/dl to maximum of 100 mg/dl and in 2 h post glucose is less than 140 mg/dl and in diabetic condition namely fasting blood glucose minimum as 101 mg/dl to maximum of 126 mg/dl and for post condition blood glucose minimum as 140 mg/dl to maximum of 200 mg/dl was used in selection of diabetic patients (Seshiah, 2002).

The three layer network with input layer having two nodes, hidden layer having two nodes and an output layer with one node. We consider sigmoidal functions for activations for the hidden and output layers and linear activation function for input layer. The number of neuron in the hidden layer may be chosen to lie between z and 2z were z is the number of input neurons. We have already seen the benefit of the middle-hidden layer in an artificial neural network. We understand that the hidden layer allows ANN to develop its own internal representation of this mapping. Such a rich and complex internal representation capability allows the hierarchical network to learn any mapping and not just linearly separable ones. Let us consider the three-layer network with input layer having 'i_i' nodes, hidden layer having 'm_i' nodes, and an output layer with 'n_i' nodes. We consider sigmoidal functions for activation functions for the hidden and output layers and linear activation function for input layer. The number of neurons in the hidden layer may be chosen to lie between z and 2z. The basic algorithm loop structure is given as:

Initialize the weights

Repeat

For each training pattern

Train on that pattern

End

Until the error is acceptably low

The algorithm illustrates the step by step procedure of the back propagation algorithm.

Step 1: Normalize the inputs and outputs with respect to their maximum values. It is proved that the neural networks work is better if input and output lie between 0-1. For each training pair, assume there are two input nodes given by { I_{i1}, I_{i2} }_i and one output node {O_o}_o in a normalized form.

Step 2: Assume the number of neurons in the hidden layer to lie between z<m_i<2z.

Step 3: [V_i] represents the weights of synapses connecting input neurons and hidden and [W_o] represents the weights of synapses connecting hidden neurons and output neurons. Initialize the weights to small random values usually from -1 to 1. For general problems slope value can be assumed as 1 and the threshold values can be taken as zero.

$$[V_i]^0 = [\text{random weights}]$$

$$[W_o]^0 = [\text{random weights}]$$

$$[\Delta V_i]^0 = [\Delta W_o]^0 = [0]$$

Step 4: For the training data, present one set of inputs and outputs. Present to the pattern to the input layer { I_i }_i as inputs to the input layer. By using linear activation function, the output of the input layer {O_i}_i may be evaluated as

$$\{O\}_i = \{I\}_i$$

Step 5: Computes the input to the hidden layer by multiplying the corresponding weights of synapses as

$$\{I\}_H = [V_i]^T \{O\}_i$$

Step 6: Let the hidden layer units evaluate the output using the sigmoidal function as

$$\{O\}_H = \left\{ \frac{1}{(1 + e^{-I_{Hij}})} \right\}$$

Step 7: Compute the inputs to the output layer by multiplying the corresponding weights of synapses as

$$\{I\}_o = [W_o]^T \{O\}_H$$

Step 8: Let the output layer units evaluate the output using the sigmoidal function as

$$\{O\}_o = \left\{ \frac{1}{(1 + e^{-I_{Oj}})} \right\}$$

The above is the network output.

Step 9: Calculate the error and the difference between the network output and the desired output as for the kth training set as

$$E^p = \frac{\sqrt{\sum (T_j - O_{Oj})^2}}{n_i}$$

Step 10: Find {d} as

$$\{d\} = \{(T_k - O_{ok}) O_{ok} (1 - O_{ok})\}$$

Step 11: Find [Y] matrix as

$$[Y_o] = \{O\}_H <d>$$

Step 12: Find $[\Delta W_i]^{t+1} = \alpha[\Delta W_i]^t + \eta [Y_o]$

Step 13: Find {e} = [W_i] {d}

$$\{d^*\} = \{e_i (O_{Hi}) (1 - O_{Hi})\}$$

Find [X] matrix as

$$[X] = \{O\}_i <d^*> = \{I\}_i <d^*>$$

Step 14: Find $[\Delta V_i]^{t+1} = \alpha[\Delta V_i]^t + \eta [X_i]$

Step 15: Find $[V_i]^{t+1} = [V_i]^t + [\Delta V_i]^{t+1}$
 $[W_i]^{t+1} = [W_i]^t + [\Delta W_i]^{t+1}$

Step 16: Find error rate as

$$\text{Error rate} = ((\sum Ep) / (n_i \text{ set}))$$

Step 17: Repeat steps 4-16 until the convergence in the error rate is less than the tolerance Value.

Where α is momentum factor, η is learning rate, $[\Delta V_i]^0$ is initial weight of the arm input layer to hidden layer, $[\Delta W_i]^0$ is initial weight of the arm hidden layer to output layer, $[\Delta V_i]$ is change in weight of the arm input layer to hidden layer, $[\Delta W_i]$ is change in weight of the arm hidden layer to output layer, $[\Delta V_i]^{t+1}$ is the new weight of the arm input layer to hidden layer, $[\Delta W_i]^{t+1}$ is the new weight of the arm hidden layer to output layer and E_p is error for each iteration. Leading to a linear optimization problem that could be solved by ordinary least squares method. This avoids the problem of gradient descent methods and local minima characteristic of back propagation algorithm is used (Curry & Morgan, 1997).

Result and discussion

Of the 700 cases, a random sample of 400 cases (57%) was used as training the network, 200 cases (28%) for validation and 100 cases (15%) for testing. Training data were used to train the application, validation data were used to monitor the neural network performance during training and the test data were used to measure the performance of the trained application. Of the 700 cases two-third (66.7%) and 32.3% had family history of diabetes. Gender composition and family history of diabetes were similar in both the diabetic and non-diabetic groups. Table 1 summarizes the comparative predictions between different blood glucose group values of means \pm standard error of samples with clinical data.

Conclusion

Management of Diabetes mellitus is mainly based on the continuous analysis of blood glucose level. Neural

network based non- invasive glucometer is a powerful technique that could significantly improve the existing blood glucose determination techniques. The neural network model had a better predictive power. This study indicates the good predictive capabilities of back propagation neural network. Back propagation neural network remains the clear choice when the primary goal of model development is look for possible causal relationships between independent and dependent variables and one wish to easily understand the effect of predictor variables on the outcome. There have been ingenious modifications and restriction to the neural network model to broaden its range of applications. The network model will often deliver the close to the best fit and the present work was motivated in this direction. Case studies show that neural network based non-invasive glucometer could benefit medical diagnosis and treatment of diabetes because it could give more accurate results nearly 99.69% to the clinical value and it is non-invasive. A prominent advantage of wavelet based neural network non-invasive blood glucose diagnosis is easy handling.

Table 1. Summary of the comparative predictions between different blood glucose groups with clinical data

Groups	subjects	Practical outputs (mg/dl)	clinical outputs in (mg/dl)	Accuracy in %
Group 1 (0-150 mg/dl)	ASK	133.0607±15.8	133±16.2	99.95
	ANA	143.3306±16.2	143±16.8	99.77
Group 2 (151-250 mg/dl)	VAJ	220.6206±17.0	220±19.3	99.72
	VAN	223.3953±20.2	223±18.7	99.82
Group 3 (251-350 mg/dl)	JAN	308.4323±19.1	307±20.1	99.54
	NIR	310.143±20.2	309±20.5	99.63
Group 4 (351-450 mg/dl)	SHA	392.922±21.3	392±21.4	99.77
	NET	405.123±25.6	404±20.9	99.72
Group 5 (451 & above mg/dl)	PRK	514.527±24.3	512±25.3	99.51
	VCS	521.6116±26.1	520±24.8	99.69

References

1. Rumelhart DE, Hinton GE and Williams RJ (1986) Learning representation by back propagating errors. *Nature*. 323, 533-536.
2. Ashok V, Nirmalkumar A and Jeyashanthi N (2010a) A novel method for blood glucose measurement by non-invasive technique using laser. *Int. J. Biol. Life Sci.* 127-133.
3. Ashok V, Balakumaran T, Gowrishankar C, Vennila I and Nirmalkumar A (2010b)“The fast Haar wavelet transform for signal and Image processing. *Int. J. Comp. Sci. Inform. Security*. 7(1), 126-130.
4. Seshiah V, Balaji V, Madhurai R and Aruna S (2002) Diagnosis of Diabetes mellitus-rationale for glucose challenge. *Antiseptic*. 99, 272-274.
5. Curry B and Morgan P (1997) Neural networks: a need for caution. *Omega Int. J. Management Sci.* 25,123-133.