



Impact of distributed generation on distribution system's reliability considering recloser-fuse miscoordination-A practical case study

Seyed Ali Mohammad Javadian and Maryam Massaeli

Department of Electrical Engineering, Islamic Azad University, Islamshahr Branch, Tehran, P. O. Box 3135-369, Iran
javadian@ieee.org; maryam_massaeli@hotmail.com

Abstract

Using Distributed Generation (DG) is an interesting topic that has drawn attention of electrical engineers in recent years. The presence of these generation units in distribution systems, although has many advantages and benefits, has to be applied after performing detailed studies and investigations due to their complexities in operation, control and protection of network. DGs are connected to distribution networks with the aim of reliability improving. On the other hand, installation of DG may destroy the protection coordination which causes the system reliability to become worse. This conflict has been investigated on a practical distribution system in Iran and the results have been presented. Because of the large number of temporary faults in the studied feeder and their long repair time, which is because of special recloser-fuse coordination scheme of the feeder, reliability analysis is done considering both permanent and temporary faults.

Keywords: Distributed Generation; Distribution System; Protection; Reliability.

Introduction

Conventional electric distribution systems are radial in nature, supplied at one end through a main source. These networks generally have a simple protection system usually implemented using fuses, re-closers, and over-current relays. Considerable attention has recently been paid to the use of Distributed generation in electric distribution systems. Presence of such sources in a network may lead to losing coordination of protection devices. This problem can drastically deteriorate the system reliability, and it is more serious and complicated when there are several DG sources in the system. Hence, the above conflict in reliability aspect unavoidably needs a detailed investigation before the installation or enhancement of DG is done (Javadian & Haghifam, 2008).

DGs are distributed generation units of electric power connected to distribution network. Compared with large generators and power plants, they have smaller generation capacity and run at lower operational costs. Besides, application of DGs has many advantages, such as better economy in comparison with the development of large power plants, reduced environmental pollution, higher efficiency, improved quality of electric supply to consumers, reduced loss in distribution systems, improved voltage profile, and releasing of network capacity. Hydro and wind turbine, solar thermal, photovoltaic arrays, fuel cells, biomass gasification, micro-turbines, battery storage, and geothermal are the most significant technologies for DG (Barker & de Mello, 2000).

The presence of DGs in distribution networks, like many other technologies, has some disadvantages along with many advantages it can have (Dugan & McDermott, 2002). Among advantages of DGs one can mention improvement in power quality and reliability and reduction of loss, meanwhile using DGs leads to complexity in

operation, control and protection of distribution systems (Kauhaniemi & Kumpulainen, 2004). Injection of DGs currents to a distribution network results in losing radial configuration and consequently losing the existing coordination among protection devices (Girgis & Brahma, 2001). The extent at which protection coordination is affected depends on the size, type and location of DG, in some cases coordination is lost completely and in other cases the coordination range diminishes (Doyle, 2002). Regarding the influence of DGs on protection of distribution systems, many researches have been performed so far as well as some researches concerning how to tackle the resultant problems of applying DGs (Hadjsaid *et al.*, 1999).

The promotion of DG is derived not only from its commercial purpose, but also from its power quality improving ability and environmental friendly attribute. Regarding power quality, DG can be applied as backup generation, in addition to its normal operation, when the main supply is interrupted. Without the upstream source, system isolation is formed and obtains electricity supply from the DG located in the connected area. As backup generation, DG is supposed to improve the system reliability if the related concerns are deliberately considered and the solutions are strictly implemented. For example, the isolated area must be able to maintain its own voltage and frequency within the specified standard. Also, the existing protection coordination in the system must not be jeopardized from the installation of DG (Chaitusaney & Yokoyama, 2006).

In this paper, this conflict has been investigated on a practical distribution network in Iran using DlgSILENT Power Factory 13.2. The paper assumes that all prerequisite requirements of DG installation are satisfied, except for the problem of recloser-fuse miscoordination that significantly impacts the reliability of desired distribution system.

In the study, three reliability indices are evaluated in all defined scenarios, which are as follows:

- SAIFI (System Average Interruption Frequency Index)
- SAIDI (System Average Interruption Duration Index)
- ENS (Energy Not Supplied)

After a short description of recloser-fuse miscoordination problem, the proposed method for reliability analysis of distribution system with distributed generation is briefly introduced, and finally, the method is implemented on a practical distribution feeder in Iran and the simulation results are presented.

Problem of recloser-fuse miscoordination

Fig. 1. Recloser-Fuse coordination

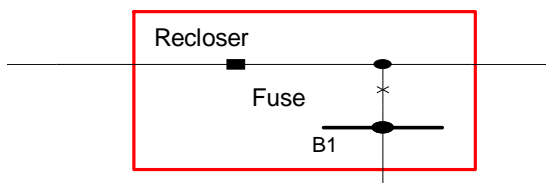

Fig.2. Recloser-Fuse coordination

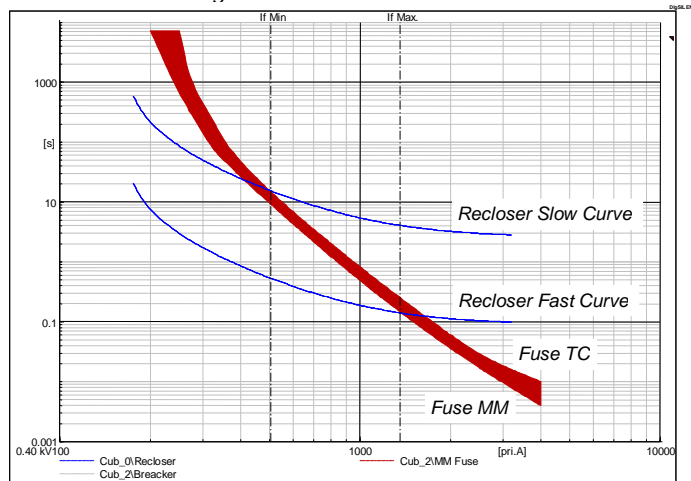

Fig.1 and Fig.2 show traditional recloser-fuse coordination in a distribution system. Fig.1 shows a fuse in the lateral feeder and a re-closer which is located on the main feeder. In order to have a correct operation, the fuse must be coordinated with upstream re-closer on the main feeder. The coordination philosophy here is that the fuse should only operate for a permanent fault on the load feeder. For a temporary fault, re-closer should disconnect the circuit with fast operation and give the fault a chance to clear. Only if the fault is permanent, the fuse should be allowed to open. In this way, the load feeder does not get disconnected for every temporary fault. Re-closer also provides back up to fuse through slow mode. Since temporary faults constitute 70% to 80% of faults occurring in distribution system, this arrangement improves reliability while decreasing the maintenance cost. Figure 2 shows the recloser-fuse coordinated graph for all fault

currents within I_{fmin} and I_{fmax} . This is called the coordination range. Therefore, as long as the fault current values for faults on lateral feeder are within the coordination range, the recloser-fuse coordination is considered to be acceptable. It can be seen from figure 2 that fast characteristic of the re-closer lies below the MM characteristics of fuse between I_{fmin} and I_{fmax} . Therefore, in coordination range the re-closer operates in less time than the time sufficient to damage the fuse.

Typical operating sequence of a re-closer is F-F-S-S (where F stands for fast and S for slow). There is an interval between each operation when the re-closer remains open. If the fault is temporary, it will be cleared before the re-closer closes after the second fast operation (if the 'open' time of re-closer is assumed as one second, this time will be more than two seconds). If the fault persists after the re-closer closes following the second fast operation, then the fault has to be a permanent one and hence fuse must operate to clear the fault. As shown in Fig. 2, the TC curve of the fuse is below the slow curve of re-closer in coordination range. Therefore, for a permanent fault, fuse will open before re-closer operates in the slow mode. If the fuse fails to operate, re-closer will back it up by operating in the slow mode and finally locking out (Girgis & Brahma, 2001).

Penetration of DG currents results in not having a radial distribution network, and consequently losing protection coordination. Hence, presence of these kinds of energy resources will change the protection coordination range in some cases while in other cases it will result in losing it. Maximum and minimum fault currents for a fault on the load feeder will change and for any fault on load feeder, fuse will see more current than the re-closer. In addition, as conventional protection, a temporary fault, occurring mostly at lateral feeder, should be discriminated by the fast operation of re-closer. However, this conventional scheme may not be held when DG is connected at the end of the feeder. It is possible that this temporary fault is cleared by the lateral fuse, and be changed to a permanent fault. These undesirable operations of protective devices called "Fuse Blowing" and certainly decrease the system reliability.

Fig. 3. Alternative cases

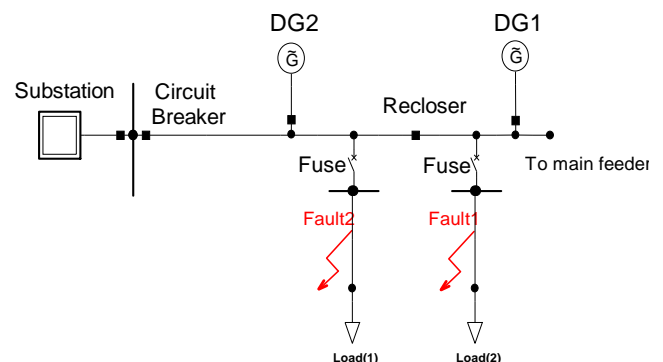

In order to clarify the consequence of injected current, depending on placement of DG toward the re-closer, four different cases are depicted in Fig.3 and tabulated in Table 1.

Table 1. Alternative cases

Case	DG Unit	Fault Location
1	DG 1	Fault 1
2	DG 1	Fault 2
3	DG 2	Fault 1
4	DG 2	Fault 2

In case 1, fault current seen by the fuse is vector summation of both fault currents from the substation and the DG. It indicates that system problem will occur whenever both DG source and fault position are located behind the re-closer. This is the case of fuse blowing above mentioned. With this situation, it is possible that the un-coordination of re-closer and fuse will happen (Chaitusaney & Yokoyama, 2006).

In case 2, DG and fault location are respectively after and before the re-closer. In this case, reverse current flows through the re-closer and fuse should operate first. However, it is possible that the re-closer at the fast mode will operate faster and meaninglessly cause the electricity interruption at the rear circuit. However, since the rear circuit can be automatically restored within only few cycles after the fuse has operated, it brings about only a momentary electricity interruption, which may be negligible (Chaitusaney & Yokoyama, 2006).

For case 3, the same fault current flows through the re-closer and the fuse. This seems that re-closer and fuses can coordinate properly. However, increasing the current will result in changing the coordination range, and no longer will maintain the coordination protection (Chaitusaney & Yokoyama, 2006).

At last, in case 4, both DG and fault location are upstream of re-closer and the fault current will flow to fuse directly and the re-closer will not detect anything. Fuse blowing will not occur in this case. As a result, only fuse blowing in case 1 will be investigated in this study (Chaitusaney & Yokoyama, 2006).

Fig. 4. Coordination margin after connecting DG

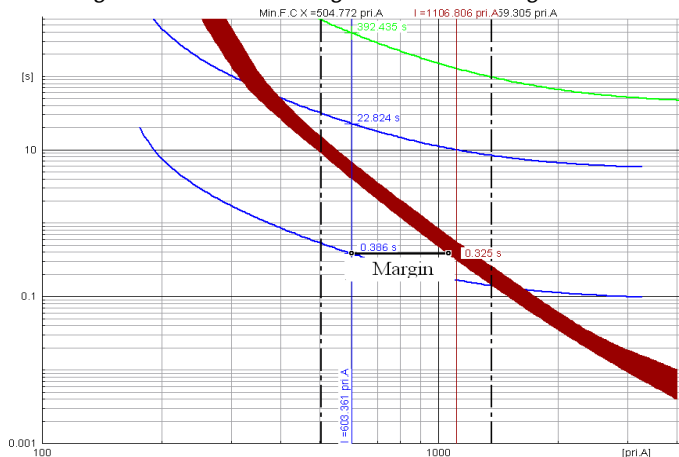

There is a difference between current flowing through the fuse and the re-closer because of contributing the DG in feeding the fault location. Naturally, the disparity between these currents depends on the size and type of DG and its placement on the main feeder. The larger the DG size, the more the fault current. Fig.4 illustrates the currents flowing through re-closer (I_R) and fuse (I_F) in a typical distribution network. If the difference between I_R and I_F exceeds the margin, for a certain fault current, fuse will blow before the first closure attempt of the re-closer and consequently the coordination will be lost (Chaitusaney & Yokoyama, 2006).

It can be shown that the margin fault current from DG can be written as (1).

$$I_{margin} = I_{fuse,margin} - I_S \quad (1)$$

Where;

I_S fault current from utility substation;

I_{margin} margin for DG fault current;

$I_{fuse,margin}$ current seen by fuse, considering the margin;

To ensure that the re-closer F will operate before fuse MM, the fault current from DG (I_{DG}) must be lower than I_{margin} . Hence, the following equation can be expressed.

$$I_{DG} < I_{margin} \quad (2)$$

Reliability analysis

For each system component, three reliability statistics are used to evaluate the system reliability, i.e. λ (average failure rate, f/yr), r (average outage time, hours), and U (average annual outage time, hours/yr). In this study, λ is assumed to be resulted only from electricity faults. Each system component will be interrupted as long as repair or switching times, depending on the location of the considered component, the location of the failed component, and the type of fault. Taking these interruption durations into account, the outage duration for the load points connecting to the interrupted component is derived. So, the outage information of load points can be directly calculated from the reliability statistics of system components. Since in this study both temporary and permanent faults, each of these three reliability statistics should be divided into two groups, i.e. permanent and temporary. Firstly, the average failure rate of each system component can be written as (3).

$$\lambda = \lambda_t + \lambda_p \quad (3)$$

Where λ_p and λ_t are the permanent and temporary average failure rates, respectively. Each of them gives its own average outage time which is r_p for permanent and r_t for the temporary faults. r_p is the repair time for permanent faults, while r_t is just few seconds in case of temporary fault. Hence, average annual outage time for both types of faults can be calculated as follows.

$$U_p = \lambda_p \times r_p \tag{4}$$

$$U_t = \lambda_t \times r_t \tag{5}$$

Finally, the total average annual outage time and average outage time can be written using (6) and (7) respectively.

$$U = U_p + U_t \tag{6}$$

$$r = \frac{U}{\lambda} \tag{7}$$

Recloser-fuse miscoordination will make permanent interruption for some of system components in case of temporary faults. For instance, lateral feeders and transformers may be interrupted as long as the repair time of fuse, used to replace the fuse blown from the miscoordination.

DG is considered as a synchronous power generator. Therefore, the fault current from DG sources will result in the recloser-fuse miscoordination in probabilistic manner depending on the operation condition and technical specifications of that DG unit. So, if the probability of protection miscoordination, p , is given, the average annual outage time for temporary faults can be formulated as (8).

$$U_t = \lambda_t \times ((1 - P) \times r_t + P \times r_p) \tag{8}$$

It should be considered that because of large number of temporary faults in the studied feeder and their long repair time, which is because of special recloser-fuse coordination scheme of the feeder, r_t cannot be neglected and reliability analysis is done considering both permanent and temporary faults.

In order to investigate the effect of recloser-fuse miscoordination on system reliability, three scenarios are defined. In the first scenario, a distribution system, in which there is no DG, is considered and reliability indices (SAIFI, SAIDI, and ENS) are calculated. In the second scenario, the same distribution system after installation of DG is considered. In this scenario, it is assumed that the

probability of protection miscoordination is zero. Finally, in the last scenario, the same distribution system after installation of DG is considered. In this case, the same reliability indices are calculated and different values for probability of protection miscoordination are considered in order to perform sensitivity analysis. The desired reliability indices can easily be calculated from (9), (10), and (11).

$$SAIFI = \frac{\text{total number of customer interruptions}}{\text{total number of customers}} = \frac{\sum \lambda_k N_k}{\sum N_k} \tag{9}$$

$$SAIDI = \frac{\text{sum of customer interruption durations}}{\text{total number of customers}} = \frac{\sum U_k N_k}{\sum N_k} \tag{10}$$

$$ENS = \text{total energy not supplied} = \sum L_{a,k} N_k \tag{11}$$

Simulation results

The investigated distribution system is named "Sanayeh 4" which is a medium voltage feeder with 12335m in length and is supplied through a 63/20 kV sub-transmission substation named "Sanayeh Substation", located in the northern Shiraz (one of the largest cities in Iran). 63/20 kV substation is located near to "Sanayeh" in Shiraz and its forth feeder supplies three parts of Shiraz named "Moali Abad", "Shaharak-e-Bahonar", and "Farhang Shahr". This feeder supplies 34 20/0.4 kV distribution substations, including 3 ground and 31 aerial substations. Single line diagram of the studied feeder is shown in Fig.5.

For all scenarios, SAIFI, SAIDI, and ENS from temporary and permanent faults can be calculated using (9)-(11), as well as SAIFI, SAIDI, and ENS of the interruption change due to the miscoordination in the third scenario. By doing so, SAIFI, SAIDI and ENS of all scenarios can be calculated by summing the SAIFI and SAIDI from permanent faults and the SAIFI, SAIDI and ENS from temporary faults as well as the SAIFI, SAIDI and ENS from change of temporary faults to permanent ones (Only in the 3rd scenario). Table 2 shows the summary results for these three scenarios. In the table, SAIFI-perm., SAIDI-perm., and ENS-perm. result from

Fig. 5. Single line diagram of the studied distribution feeder in DlgSILENT Power Factory 13.2

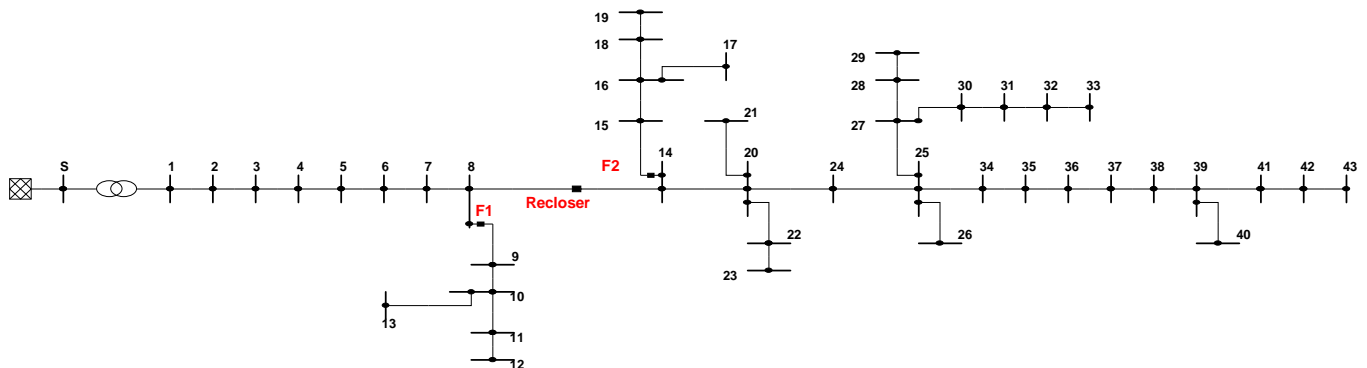

permanent faults. SAIFI-temp., SAIDI-temp., and ENS-temp. result from temporary faults as well as the change of interruption duration when the miscoordination occurs.

Table 2. Comparison results

Indices	Scenario 1	Scenario 2	Scenario 3
SAIFI-perm. (ints/cus)	0.215	0.215	0.215
SAIDI-perm. (hrs/cus)	3.857	3.517	3.517
SAIFI-temp. (ints/cus)	0.273	0.273	0.273
SAIDI-temp. (hrs/cus)	0.104	0.104	0.395
ENS-perm. (MWh)	13.802	11.998	11.998
ENS-temp. (MWh)	0.383	0.302	1.058
Total SAIFI (ints/cus)	0.488	0.488	0.488
Total SAIDI (hrs/cus)	3.961	3.621	3.912
Total ENS (MWh)	14.185	12.3	13.056

Comparing the 2 first scenarios, it is concluded that installation of DG does not affect the system reliability in term of SAIFI. This is because the protective devices should trip and disconnect the circuit in order to isolate the faulted component from the rest of the network. However, the installation of DG make system SAIDI and ENS better because it can decrease interruption duration for some of network loads by getting supplied from DG. In scenario 3, the system SAIFI is equal to the two first scenarios, whereas the system SAIDI and ENS can still be improved. These confirm the fact that installation of DG can make the system reliability better or worse.

As mentioned previously, the maximum size of DG for maintaining the existing recloser-fuse coordination can be calculated. By combination of mathematical equations of characteristics of protection devices and equation of short circuit capacity, the maximum size of the total DG can be derived. This calculation has been performed in [16] for the desired distribution feeder and it has been concluded that this threshold size of DG is approximately 591 KVA for this feeder.

Table 3. Results With DG at maximum size

Indices	Studied Feeder
SAIFI-perm. (ints/cus)	0.215
SAIDI-perm. (hrs/cus)	3.517
SAIFI-temp. (ints/cus)	0.273
SAIDI-temp. (hrs/cus)	0.104
ENS-perm. (MWh)	11.998
ENS-shed. (MWh)	1.134
ENS-temp. (MWh)	0.302
Total SAIFI (ints/cus)	0.488
Total SAIDI (hrs/cus)	3.621
Total ENS (MWh)	13.434

Table 3 shows that the reliability is better than scenario 1, and it is worse in comparison with scenario 2. Comparing with scenario 3, the system reliability is not changed in term of SAIFI. But it is improved in terms of SAIDI. However, the reliability is degraded in term of ENS. This is because some loads must be shed in the

Fig. 6. Reliability indices associated with change of DG capacity

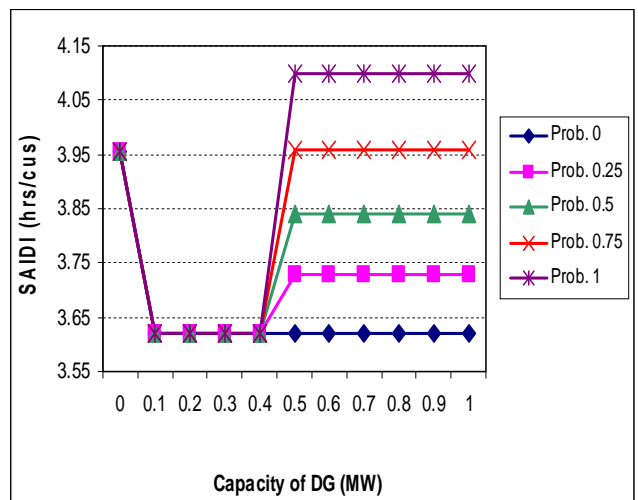
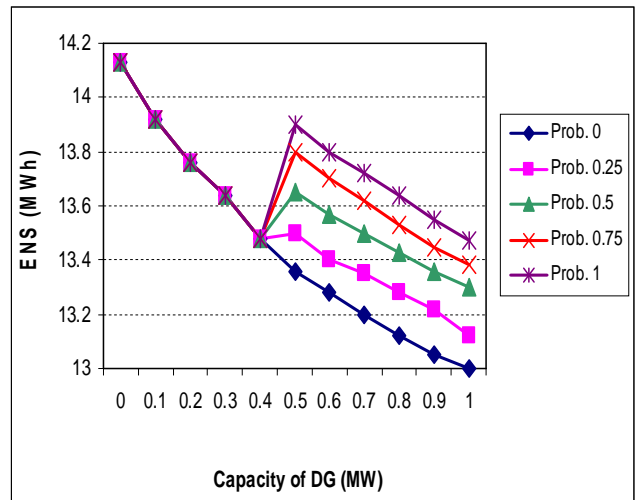
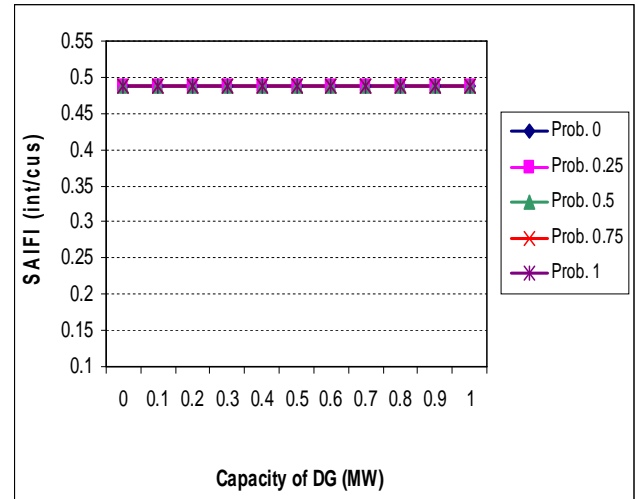

produced electric island because of the limited DG capacity.

The summary results of sensitivity analysis for the third scenario are illustrated in Fig.6. According to the figure, SAIFI does not change after connecting DG. However, SAIDI is reduced to 3.621 hours/customer, whereas ENS is reduced by increasing capacity of connected DG.

According to the threshold of recloser-fuse miscoordination, it will take place when the total DG capacity is greater than 0.473 MW. Therefore, SAIDI and ENS are degraded when the total DG capacity steps from 0.4 MW to 0.5 MW. After that, all reliability indices keep maintaining their actual response to the increase of the total DG capacity. Regarding the miscoordination probability, it can be concluded that the higher miscoordination probability is, the worse SAIDI and ENS are.

Conclusion

DGs are connected to distribution networks with the aim of reliability improving. On the other hand, installation of DG may destroy the protection coordination which causes the system reliability to become worse. This conflict has been investigated on a practical distribution system in Iran and the results have been presented. The simulation results indicate that DG can make system reliability better or worse. So, it is required to perform a detailed study before installing DG in distribution feeders to make sure that it can improve total system reliability.

References

1. Barker PP and de Mello R W (2000) Determining the impact of distributed generation on power systems: part1-radial distribution systems. *IEEE Trans. Power Delivery*. 15, 486-493.
2. Chaitusaney S and Yokoyama A (2006) Reliability analysis of distribution system with distributed generation considering loss of protection coordination. *9th Intl. Conf. on Probabilistic Methods Applied to Power Sys*. pp: 1-8.
3. Doyle MT (2002) Reviewing the Impacts of Distributed Generation on Distribution System Protection, *Power Engg. Soc. Summer Meeting, IEEE*. 1,103-105.
4. Dugan RC and McDermott TE (2002) Operating conflicts for Distributed Generation interconnected with Utility Distribution Systems, *IEEE Indus. Appl. Magaz*. pp: 19-25.
5. Girgis A and Brahma S (2001) Effect of Distributed Generation on Protective device coordination in distribution system, *Power Engineering. Large Engg. Sys. Conf. (LESCOPE'01)*. pp: 115 - 119.
6. Hadjsaid N, Canard J and Dumas F (1999) Dispersed generation impact on distribution networks. *IEEE Comput. Appl. Power*. 12, 22-28.
7. Javadian SAM and Haghifam MR (2008) Designing a new protection system for distribution networks including DG. *9th IET Intl. Conf. on Developments in Power Sys. Protect*. pp: 675-680.
8. Kauhaniemi K and Kumpulainen L (2004) Impact of distributed generation on the protection of distribution networks, *Developments in Power System Protection, Eighth IEE Intl. Conf.* 1, 315 - 318.