

## An adaptive overcurrent protection scheme for distribution networks including DG using distribution automation system and its implementation on a real distribution network

Seyed Ali Mohammad Javadian and Maryam Massaeli

*Department of Electrical Engineering, Islamic Azad University, Islamshahr Branch, Tehran, P. O. Box 3135-369, Iran  
javadian@ieee.org, maryam\_massaeli@hotmail.com*

### Abstract

Recently, a great attention has been paid in applying Distributed Generation (DG) throughout electric distribution systems. Although DG has many advantages and benefits, it has to be applied after performing detailed investigations due to their complexities in operation, control and protection of network. One of the most considerable problems that arise, when DGs are used, is destructing efficiency and qualification of the existing protection system. The injected currents of DGs to a distribution network lead to not having a radial network anymore, and consequently network faces an inefficient protection system that was formerly designed according to the existing philosophy behind the distribution network. In this paper, a new protection scheme has been presented to provide the distribution networks including DGs. The new approach, designed based on capabilities of Distribution Automation System (DAS), has been implemented using a computer-based relay which is installed in the sub-transmission substation. The proposed scheme has been implemented on some part of a real distribution network in Shiraz which is a large city in Iran and performance of the proposed scheme is tested on it. For simulating the distribution network and for implementing the relay algorithm, DlgSILENT Power Factory 13.2 and MATLAB are used respectively.

**Keywords:** Distribution System, Distributed Generation, Protection, Distribution Automation, Shiraz

### Introduction

Traditional electric distribution systems are radial in nature, and are supplied through a main source, therefore it is simple to design protection scheme for such networks. Recently, great attention has been paid in applying Distributed Generation (DG) throughout electric distribution systems, and presence of these generation units results in not having a radial distribution network, consequently raises some problems such as losing coordination of protection devices (Brahma & Girgis, 2004).

Generally, problems that arise due to application of DGs are: false tripping in feeders, false tripping in generation units, protection blinding, increasing and decreasing short circuit levels, undesirable network islanding and preventing automatic and asynchronous reclosing (Barker & de Mello, 2000). Appearance of these problems depends on the characteristics of network and DGs and in most cases network protection scheme must be thoroughly changed in order to avoid the mentioned difficulties. Such changes may be complicated, since it is needed to model whole distribution system including distribution network in addition to DG, consequently obtaining the best protection scheme is still difficult (Dugan & McDermott, 2002).

When DG units are connected to a distribution network, the system will be radial no longer and this means losing the existing coordination among network protection devices (Kauhaniemi & Kumpulainen, 2004). The extent in which a DG affects protection coordination depends on DGs' capacity, type and installation location of them (Girgis & Brahma, 2001). Due to generation capacity and installation location of DG, there are ranges in which protection coordination is maintained and in

some cases no protection coordination can be achieved (Doyle, 2002). Regarding the influence of DGs on protection of distribution systems, not enough investigations made so far. In this paper, a new protection scheme for distribution systems in presence of DGs is proposed after computer-based relay which is installed in sub-transmission substation. The relay determines system's status after it receives the required network data, and in case of fault it diagnoses its type and its location and finally issues the proper commands for protection devices to clear the fault and to restore the network.

### General view of the proposed protection scheme

The main purpose of a protection scheme is to diagnose the faulty part and isolate it from the rest of the system. In traditional distribution systems, when a fault occurs in a specific part of it, whole downstream network is disconnected from the rest of the system, or it is supplied through network tie lines. Assuming it is impossible to supply through other parts of network and a DG exists in the downstream network of the faulty part, according to conventional protection logic, it will not be possible to utilize the DG any more. This will result in not to be able to apply DG sources optimally, and amount of ENS (Energy Not Supplied) in network increases and consequently system reliability decreases. Thus, in proposed scheme, general approach is to utilize DGs to the fullest in island operation in the case of fault occurrence.

In the suggested scheme, Distribution system is divided into several zones in such a way that in each zone there is no DG, or if there is any, balance of generation and consumption in that zone is possible regardless of main network, and only using the power

generated by DGs that exist in that zone. In other words, distribution system is divided into two categories that have the following characteristics: First category includes those zones which have no DG and their loads are fully supplied through the main network and other zones of distribution network. Second category includes those zones which have at least one DG; it is obvious that at least one generation unit in that zone must be equipped with frequency control system in order to be capable of controlling zone frequency in the case that the zone is in island operation mode.

A number of circuit breakers are placed in network to interconnect the zones. These breakers have fast and consecutive open and close capability as well as receiving remote open and close command. Besides, these breakers must be equipped with check-synchronization function, to be able to maintain zones synchronization when it is needed to connect two island zones. To implement the proposed algorithm, a computer-based relay which is capable of performing calculations and storing data must be installed in sub-transmission substation. This relay is able to receive required input data (that are provided through measuring some network parameters), to process them, and finally, to diagnose location and type of fault in order to send proper commands to protection devices.

The required input data for correct operation of relay are: 1. Technical characteristics of all network devices such as distribution substations, loads, lines and DGs; 2. Data regarding network zoning; 3. All operational data of

the main relay in different faults occurrence. To implement the proposed protection scheme, it is required to carry out the following measurements and continuously providing the results for the main relay: 1. Synchronized three-phase current vectors flowing through all DGs and through main source; 2. Synchronized three-phase current vectors flowing through laterals, except those branches that have DG; 3. A signal which is indicative of current direction flowing through the zone-forming breakers. Fig. 1 shows the general schematic of proposed algorithm.

**Dividing network into separate protection zones**

Network zoning is performed to tackle with occurred faults considering two major targets, first having the ability to separate faulty zone from the rest of the system, and second supplying the network as far as it is possible. Having in mind the point that after connecting DGs to a radial distribution system, the physical structure of the system still remains radial, consequently when a protection device trips, electrical connection between upstream and downstream networks of the device is cut off. Therefore, it is required to establish a network zoning scheme which is capable of exploiting the DGs located in the downstream network in island operation, as well as supplying DGs' nearby loads to the maximum extent. Network zoning approach in this paper is based on considering one zone for each DG that begins from DG's bus bar and extends toward the end of feeder. Zone extends as far as the total estimated average load of all the substations located in the zone is equal to maximum capacity of zone's DG. While zone extends toward downstream network, it must be extended toward upstream network in the case that zone reaches the end of feeder and DG's generation capacity is still larger than total average load of substations located in the DG's zone, till the balance between DG's capacity and average load is maintained. It must also be taken into account that if during zone extension toward the downstream network for one DG, there exists another DG before violation of maintaining the balance between DG's capacity and substations' total average load, the second DG is regarded within the first DG's zone and the zone extends to the point that substations' total average load is equal to summation of two DGs generation capacity. When zoning approach is complete and zones are determined, it is required to place two isolating circuit breakers at the beginning and the end of each zone to separate the faulty zone from the rest of network whenever a fault occurs. After zoning, distribution system is divided into two categories of zones:

First category includes the zones that encompass DGs and the following condition applies to them:

$$\sum_i P_{DG_i} = \sum_i P_{L_i,average} \quad (1)$$

The significant point concerning this category of zones is that at least one DG in each zone must be equipped

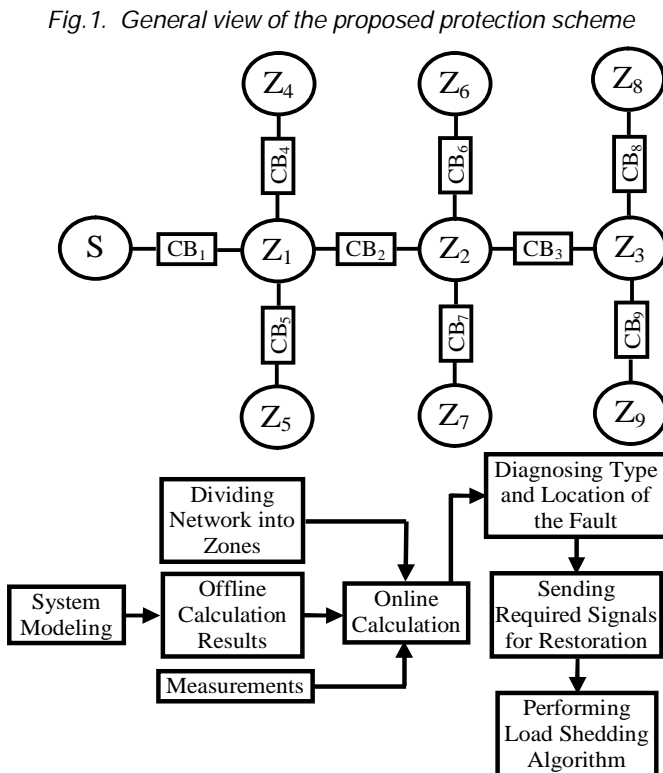



with load frequency control system to control the frequency of the island in the case of fault occurrence. Regarding the technical point that only synchronous generators have frequency control capability, in this paper it has been assumed that all connected DGs to distribution system are synchronous generators and other types of DGs such as induction generators and inverter-based systems have not been modelled.

Second category of zones comprises those zones with no DG in them and are located among the zones with DGs, loads in such zones is supplied through adjacent zones and the main source of supply.

The reason to consider zoning procedure from the beginning of feeder toward its end is to allow more loads to be supplied through upstream network. This approach increases network reliability and decreases total ENS of the system. Of course, when DG's capacity is higher than the loads located in its downstream network, zone extension border should be considered upward.

The reason to support the idea of considering average load in zoning is that in distribution systems, daily consumers' loads are variable to a great extent. In other words, hourly curve of consumers loads, and consequently substations loads, have so many maximum and minimum points in such a way that peak load might be four times of base load. Regarding the fact that duration of peak load is short, if zoning is done based on peak load, vastness of zones containing DGs will be very small, and therefore more consumers will face power cut when a fault occurs in the system. On the contrary, if average load is considered as the basis of zoning instead of peak load, vastness of zones containing DGs will increase which will result in giving distribution system consumers more chance of being supplied in the case of fault occurrence. It is required to mention that if this procedure is chosen for zoning; all distribution system loads (i.e. all distribution substations) must be equipped with load break switch. This enables central relay to supply system loads regarding their importance and to disconnect some of them to maintain the balance between generation and consumption in the case of fault occurrence in the peak-load time. Obviously these switches must be capable of receiving remote control commands as well.

#### **Operation algorithm of the main relay**

The algorithm for operation of main relay consists of four parts: 1. Offline calculations; 2. Online diagnosis procedure of fault location; 3. Isolation of faulty zone and network restoration; 4. Load shedding algorithm. In the following sections these four parts have been described.

##### *Offline calculations*

Offline calculations consist of load flow studies and short circuit analysis for all types of faults and in all points of network. Then for all faults, currents flowing through all DGs, main source and laterals are determined. Also characteristics of Minimum Melting (MM) and Total

Clearance (TC) of all fuses in network must be stored. Using the above characteristics and storing them in relay, it is possible to perform software coordination of fuses and the reclosing operation; this will be discussed in section XIII. The time before fuses to be melted is calculated out of MM characteristics and short circuit results. It is also needed to update all calculation results for any network change. For instance, when there is a change in network configuration, like disconnection of a line, it is required to update network admittance matrix and redo load flow and short circuit analysis.

To have DGs' currents, laterals and main source for all types of faults and in all network buses, a table can be provided and through comparing the above values in this table, it will be possible to diagnose the exact location and type of fault. After diagnosis of location and type of fault, which leads to diagnosis of faulty zone, relay sends disconnection signals to appropriate breakers to isolate the zone from other zones of network and consequently the faulty zone is isolated from network. In brief, procedure of offline calculations can be stated as: 1. Receiving network data; 2. Performing load flow calculations; 3. Performing short circuit analysis for all types of faults and in all network buses; 4. Extracting all required fault currents for each type of fault and in each network buses; 5. Extracting the time which is needed network fuses not to be blown, out of MM curves.

##### *Online diagnosis procedure of fault location*

As it was pointed out before, synchronized three-phase current vectors for all DGs and main source are available and summation of these values is always equal to network load. If a fault occurs in some point of network, this summation suddenly increases and is greater than whole network load. In this situation, the main relay installed in sub-transmission substation diagnoses the fault. The situation in which summation of currents is zero shows that the occurred fault is within the protection zone of one of DGs (between DG and the location that its current is measured). In these circumstances, the main relay will not issue any command to let its own protection system isolate it from the rest of network. To detect fault location, currents of DGs, main source and lateral branches are compared with the values of the table that was provided through offline calculations. This idea was introduced in (Brahma & Girgis, 2004) for the first time, but it has some problems in diagnosis of exact location of fault and sometimes encounters error and inaccuracy regarding this issue. However, the inaccuracy in detection of fault location decreases when number of DGs increases. But, in this scheme, currents flowing through lateral branches with no DG are monitored as well, in order to ensure whether the location of fault has been determined correctly. This monitoring has two advantages: first, provides main relay with more quantitative values for doing required comparisons and consequently the error in determination of fault location

decreases considerably, second since measurements are carried out in the laterals containing no DG, for those faults that do not occur in these laterals the measured current is equal to load current and this determines that no fault has occurred in laterals. Thus it is possible to increase considerably the accuracy of proposed scheme in (Brahma & Girgis, 2004), through applying this capability.

Fig.2 illustrates the online procedure of fault location diagnosis.

Fig.2. The algorithm for determination of fault location

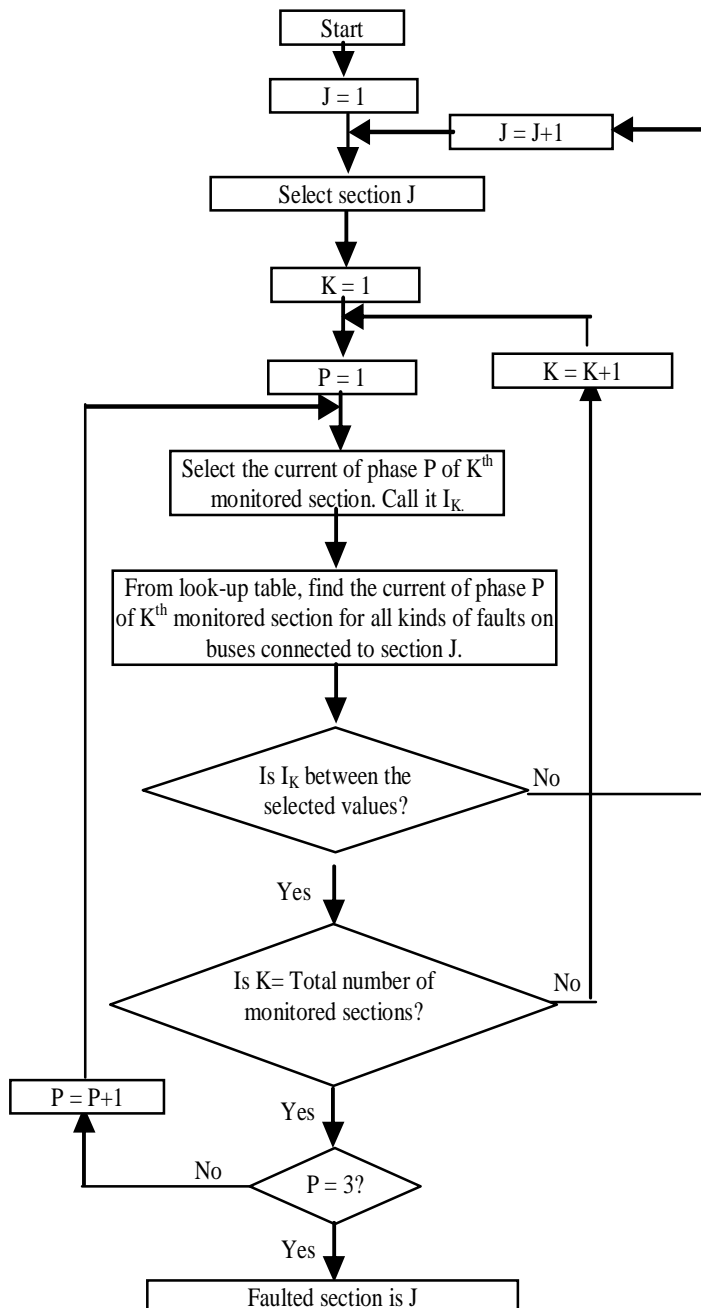

*Isolation of faulty zone and network restoration*

After relay diagnoses fault location and faulty part of network is detected, it is time to isolate the faulty zone from the rest of network and restore the network. Needed data is available in database to designate those breakers that must issue tripping signals. The general approach is that after detection of faulty zone, the relay sends disconnection signal to its isolating breakers, its downstream network's CBs and all DGs located in the faulty zone. In this situation, upstream network of faulty zone is entirely supplied through main source and its DGs, the faulty zone faces power outage and downstream zones of faulty zone are supplied through DGs within them, if that specific zone has DG or DGs, otherwise faces power outage.

Considering the fact that 80 percent of faults that occur in distribution networks are transient in nature (In this paper, faults lasting less than few seconds are classified as the transient faults.), network must be capable of letting transient faults to be cleared. In conventional distribution systems this is done using reclosers, and in the proposed scheme reclosing operation is carried out using zones isolating switches, through main relay control. The operation procedure is that after isolation of faulty section, reclosing is performed through connecting zone breaker to its upstream network at the command of main relay. After each reclosing operation, the main relay investigates network status and if the fault still exists, relay issues disconnection command. In the case that fault is transient and is removed during reclosing operation, relay issues reclosing as well as synchronization and restoration commands. To have a successful process, it is required to perform reclosing operation before fuses of network are beginning to melt. Regarding the point that MM curves of all fuses are available in relay database, and the time to avoid fuse blowing has been determined as a result of offline calculations, consequently relay can perform reclosing operation at proper time. Besides, reclosing operation must be coordinated with fuses' characteristics. To achieve this coordination, MM and TC curves of all fuses are stored in relay and relay determines and issues the best disconnection time of related breaker using different types of faults, their respective currents and curves of fuses.

For example, in Fig.1, if a transient fault occurs in  $Z_2$ , relay first sends disconnecting signal to  $CB_{21}$ ,  $CB_{31}$ ,  $CB_{61}$ ,  $CB_{71}$ ,  $CB_{81}$ ,  $CB_{91}$  and all DGs located in  $Z_2$  and then sends reclosing signal to  $CB_{21}$  to diagnose transient fault. In the end, after clearance of fault, relay sends closing signal along with synchronization to  $CB_{31}$ ,  $CB_{61}$ ,  $CB_{71}$ ,  $CB_{81}$ ,  $CB_{91}$  and all DGs located in  $Z_2$  to restore the network completely.

*Load shedding algorithm*

There are different methods of load estimation in distribution networks. For instance, among which one can

mention installing load recorders in different points of network that measure load at specific times and estimate network load for other times.

Due to the vastness of load estimation topic in distribution systems, this paper has not dealt with it, and for network zoning and operation of load shedding it is assumed that hourly load curves for all substations of distribution network have been estimated before, and are available for performed studies.

When it came to zoning issue, it was stated that operation of load shedding must be performed when network faces two conditions. First, a fault occurs in a zone where there exists at least one zone in its downstream network, including one or more DGs, and the zone goes into island operation status due to the disconnection command issued by relay and consequent operation of the circuit breakers. Second, a fault occurs when the load of an island zone is higher than the generation capacity of DG or DGs within that zone, in other words the load is higher than zone's average load. In these conditions if disconnection of load does not happen, frequency of the zone operating in island status drops considerably and this leads the zone encounters power cut problem.

To perform load shedding accurately, it is required to have all loads of substations at each time as well as their degree of importance, in order to be able to determine priority of loads disconnection and maintain the balance between generation and consumption. This needs precise loads monitoring of each and every single of the existing substations in a distribution network, which is very costly and is practical in no network. Thus, it is required to apply some approximate approaches and monitoring of currents in the most appropriate points of network to make the best decision, regarding facing the lowest possible power cut in zones as well as maintaining the balance between generation and consumption. In this paper, this algorithm has been implemented using continuous monitoring of currents flowing through circuit breakers that form zones. This is done using the fact that at each time the whole load of each zone can be calculated using (2):

$$P_L = \sum_i P_{CBi} + \sum_j P_{DGj} \quad (2)$$

In this equation  $\sum P_{CBi}$  indicates the whole power flows into zone and  $\sum P_{DGj}$  indicates the whole power of all DGs placed in that zone. It is obvious that negative value of  $\sum P_{CBi}$  for a specific zone shows that generation in that zone is higher than load of that zone and the zone exports energy to other zones. Considering the point that at each time relay monitors powers following through DGs and isolating breakers of zones, it can determine instantaneous difference between generation and load of each zone, through calculating instantaneous  $\sum P_{CBi}$ . Therefore, when network faces a fault, relay can determine whether there is shortage or excess of load in

zones including DG, using these values for the time exactly before occurrence of fault. For those zones that must operate in island status and their generation is more than their consumption, relay does not shed any loads and lets zones' DGs maintain the balance between generation and consumption through frequency control system existing in each zone. But, relay performs load shedding operation when there is overload within the zone. Relay sends disconnection command to load break switches of loads through considering a safety factor (for instance 1.1), and also considering importance of loads as well as the estimated values of loads at the time that fault occurs. The following equation shows the load that must be disconnected in each zone:

$$P_{cut} = SF \times \sum_i P_{CBi} \quad (3)$$

It might be possible to implement this idea through modeling only some part of network loads and placing load break switches for those loads (the loads that have

Fig.3. Load shedding algorithm of the main relay

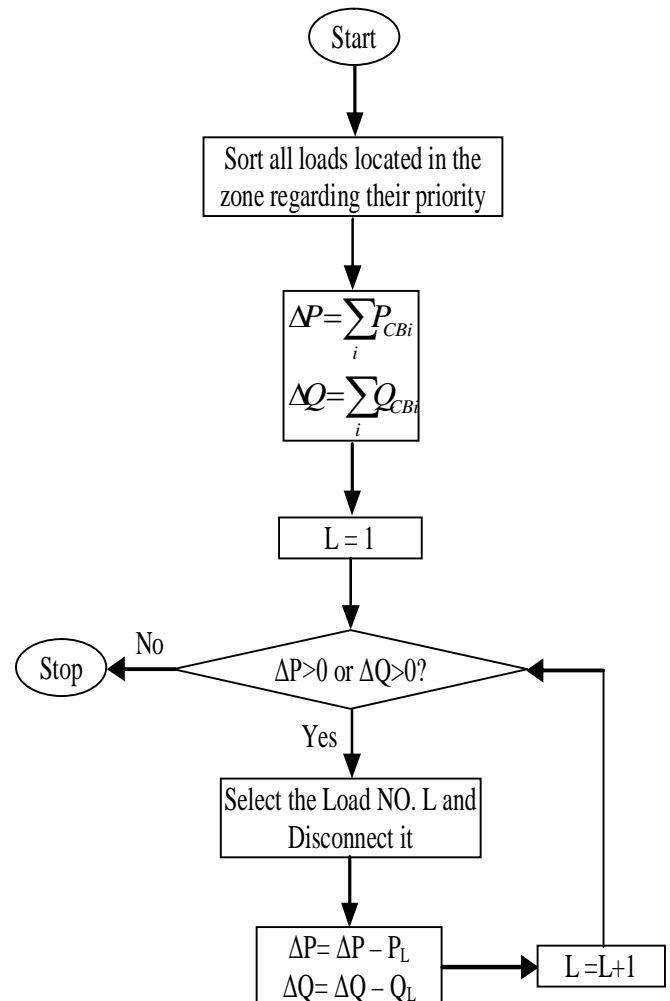

lower importance and their summation is equal to the difference of peak and average loads of each zone). Obviously, this is simpler and regarding economic considerations, it has lower costs. But, it is important to note that through placing load break switches for all loads of those zones that contain DG, flexibility of protection scheme increases considerably, in such a way that if generation capacity of DGs of a zone decreases (for any reason) or even if DGs go out of operation (due to forced outage or for maintenance), there is no need to change the protection algorithm of relay and the designed protection system will be still effective. For instance if there are two DGs located in one zone, and one of them goes out of operation, it is possible the remaining DG not to be able to supply load, even in minimum load regime. In this situation, the main relay disconnects loads till the balance between generation and consumption is achieved. Of course, for this situation, and for the situation in which there is only one DG in a zone, and the DG has gone out of operation for any reason, it is needed to update network data and redo offline calculations for the new network in order the relay avoids wrong diagnosis of fault location. Apparently, for the situation in which there is only one DG in a zone and that DG has gone out of operation, the zone can be regarded as second type of zone (zones without DG) to be needless of operation of load shedding in that zone.

Fig.3 illustrates the load shedding algorithm of the main relay.

#### Implementation of the protection scheme on real distribution network

Proposed algorithm in this paper has been implemented using MATLAB and a software application has been provided to implement designed protection scheme and to simulate operation of main relay installed in sub-transmission substation. To show the accuracy in operation of proposed protection scheme, this part deals

Fig.4. Geographical position of the studied distribution feeder in its surrounding network



with real data of an existing distribution network which belongs to some part of a large distribution system of a city named Shiraz in Iran. The studied part of network in question has been simulated using the provided software application and operation of designed protection scheme has been investigated on this network. The sample distribution network is named "Sanayeh 4" which is a medium voltage feeder with 12335m in length and is supplied through a 63/20 kV sub-transmission substation named "Sanayeh Substation", located in the northern Shiraz. 63/20 kV substation is located near to "Sanayeh" in Shiraz and its forth feeder supplies three parts of Shiraz named "Moali Abad", "Shahrak-e-Bahonar", and "Farhang Shar". This feeder supplies 34 20/0.4 kV distribution substations, including 3 ground and 31 aerial substations. Fig.4 shows geographical position of the feeder in its surrounding network.

Hourly Load curve of the studied distribution network in a typical day and load of the feeder's buses in its average load regime can be seen in Fig.5 and Fig.6 respectively.

Fig.5. Hourly Load curve of the studied distribution network in a typical day

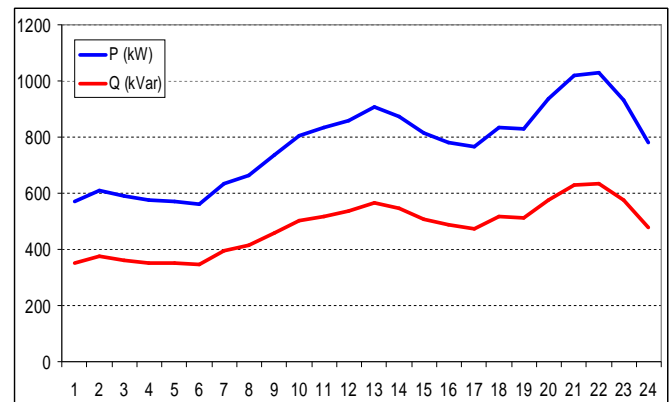

Fig.6. Load of feeder's buses in its average load regime

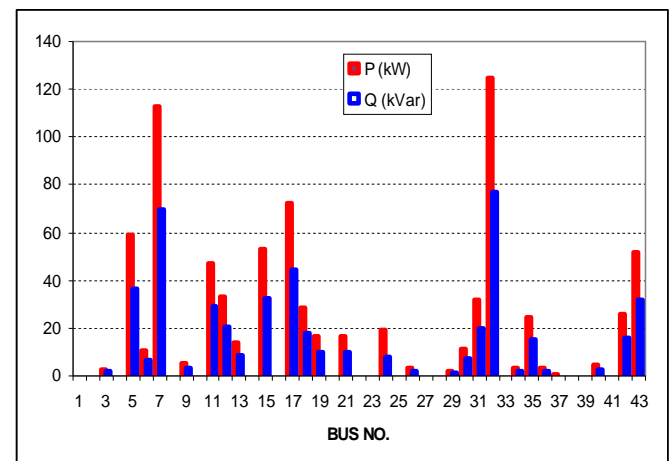
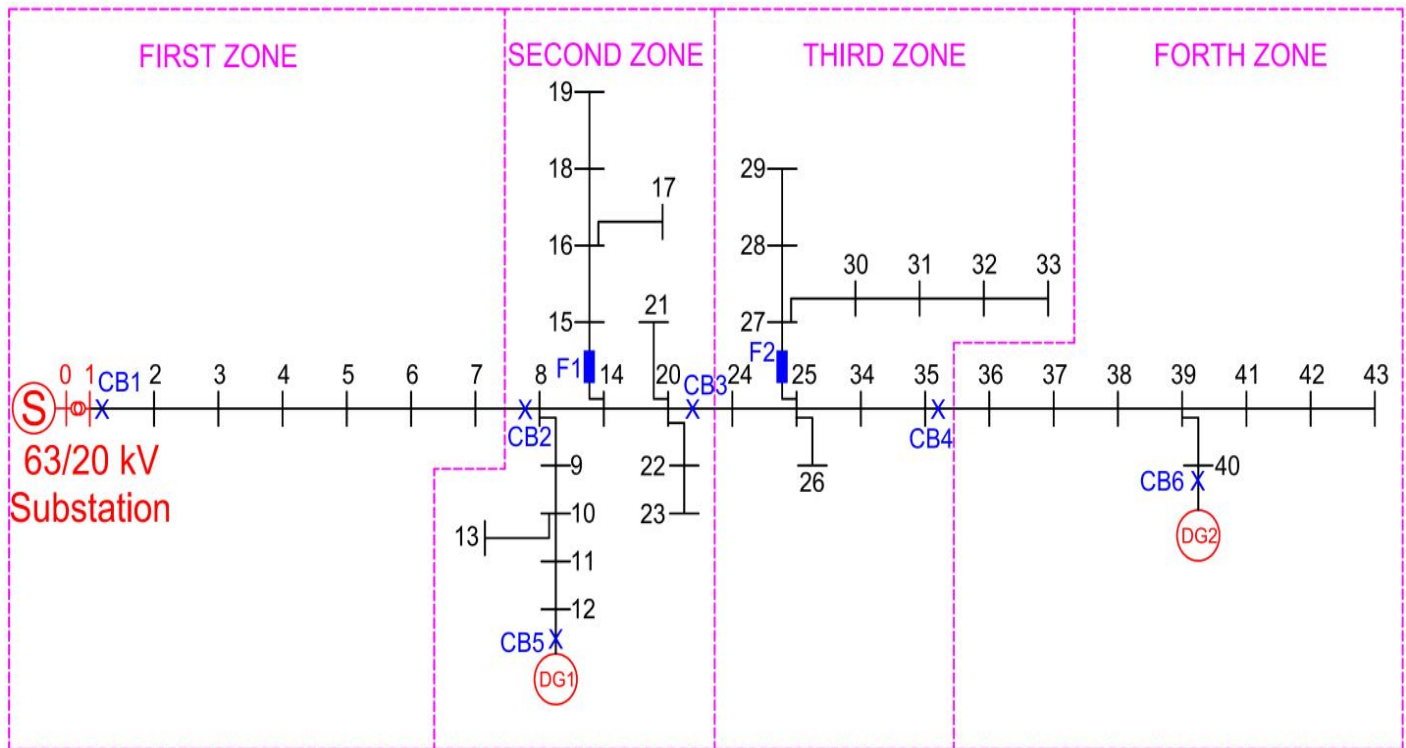

Fig.7. Single line diagram of the studied distribution feeder and its zoning after connection of DGs in the second scenario



Three scenarios have been defined for testing the operation of the designed protection approach: 1. Connecting a 350 KVA Synchronous generator to the bus 26; 2. Connecting a 500 KVA Synchronous generator to the bus 12, and a 150 KVA Synchronous generator to the bus 40; 3. Connecting a 500 KVA Synchronous generator to the bus 12, a 350 KVA Synchronous generator to bus 23, and a 150 KVA Synchronous generator to the bus 40.

In all defined scenarios, all kinds of faults, in various points of the feeder, and in different times have been simulated and operation of the system has been tested for each situation. Simulation results show that the proposed protection system has acceptable performance in diagnosing the occurred fault location and faulted zone and is also applicable for all kinds of distributed networks with different level of distributed generation penetration.

Fig.7 shows the single line diagram and zoning approach of the studied distribution feeder as well as required circuit breakers and their location for dividing the network into protection zones in the second scenario.

In this paper, in order to presenting the sequence of the main relay's operation in case of fault occurrence along the feeder, the operations of the main relay in the case of a Symmetrical three-phase fault on the line connecting buses 37 and 38 is presented:

In the case of a Symmetrical three-phase fault on the line connecting buses 37 and 38, the relay sends disconnection commands to CB<sub>4</sub> and CB<sub>6</sub>, immediately

after it diagnoses fault type as well as it determines fault occurrence in the forth zone (Z<sub>4</sub>). Therefore, only Z<sub>4</sub> faces power cut and Z<sub>1</sub>, Z<sub>2</sub> and Z<sub>3</sub> are still supplied through main source and DG<sub>1</sub>. Then, to diagnose whether fault is transient reclosing operation is done like what was done for previous situation, except that this time relay assigns this task to CB<sub>4</sub>.

If the fault is transient and is cleared, relay sends reclosing signal to CB<sub>4</sub> to supply Z<sub>4</sub> through its upstream network. Then, closing signal is sent to CB<sub>6</sub> in parallel with network synchronization operation to put DG<sub>2</sub> into operation and network restores completely. In the case that the fault is permanent and is not cleared, CB<sub>4</sub> remains open and Z<sub>4</sub> faces power outage. Like before, regarding the point that Z<sub>4</sub> has faced power outage, consequently reclosing operation will need no synchronization. If the fault happens in the peak regime, relay's load shedding unit will send disconnection command to load break switches of substation 42 in order to maintain the balance between generation and consumption in Z<sub>2</sub>. Output result of relay simulation software application is as follows:

```
>>
The fault is single phase to ground fault.
The faulted section is section 42 which connects bus 42 to 43.
The faulted zone is zone 4.
CB4 ==> Opened
```

CB6 ==> Opened  
CB4 ==> Reclosed (fast mode)  
For Transient Fault:  
    CB6 ==> Closed (with synchronizing function)  
For Permanent Fault:  
    CB4 ==> Opened  
    Load42==> Shed  
>>

### Conclusions

In this paper, an adaptive scheme for protection of distribution networks with DG was proposed. The suggested scheme is based on using DAS capabilities, is independent of capacity and location of DGs, and updates its operation whenever there is a change in network in order to keep its efficiency. The algorithm uses network zoning approach, in which each zone is an independent section and capable of island operation whenever needed. In the proposed algorithm, after dividing distribution system into several independent zones, computer-based relay that is installed in sub-transmission substation, diagnoses exact fault location through making comparison between online measured currents and offline calculations, and sends required commands and signals to protection devices in order to isolate the faulty zone from the rest of network. Finally, when fault is cleared, network restoration along with synchronization operation is done through sending reclosing commands to circuit breakers.

The proposed algorithm was implemented on some part of a real distribution network and its operation was evaluated by simulating variety kinds of faults in different locations. The results of these simulations imply that the proposed algorithm for determining the fault's type and location has strong ability of fault locating. For instance, in the simulated network, there was just one misunderstanding in location of faults occurring on the sections connecting buses 28 to 29 and buses 31 to 32 that are both in the third zone and on the same lateral, which means it doesn't affect the relay's operation at all. The simulation results also indicate that the algorithm has the ability to perform reclosing operation as well as its coordination with fuses of network using software procedures, which is one of the strongest points of the proposed scheme. Through maintaining software coordination between the existing fuses in the network and reclosing operation, a desirable compatibility between traditional protection schemes and the new ones is achieved. The other considerable feature of the scheme is its efficiency when a generation unit goes out of operation. The reaction that is made to encounter this situation is changing the type of the zone that the disconnected DG was in. For example, in the studied distribution system, disconnection of DG2 changes the forth zone from the second category of zones to the first one. In this situation, the only change in the online tasks of the relay is that the connection of the third and the forth

zones needs no synchronization. Furthermore, in the proposed scheme, asynchronous reclosing happens under no circumstances and relay connects island zones through synchronization operation whenever needed.

The proposed idea has some weaknesses. For example, it is not able to diagnose high impedance faults. Also, in zoning approach, to ensure the accurate operation of protection scheme, zones peak loads have been taken into account, while this leads to increase of ENS when a zone has island operation and its load is not at peak. Another weak point is that number of zones increases with increase in number of DGs, consequently so many isolating circuit breakers will be needed and the scheme may not be economic. Therefore, it seems that it is inevitable to improve the algorithm through adding features and capabilities to the proposed scheme, such as: diagnosis of high impedance faults, optimal zoning approach with considering a determined number of CBs and ultimately optimum utilization of zones in their island operation.

### References

1. Brahma S and Girgis A (2004) Development of adaptive protection scheme for distribution systems with high penetration of distributed generation. *IEEE Trans. Power Delivery*. 19 (1), 56-63.
2. Barker PP, de Mello RW (2000) Determining the impact of distributed generation on power systems: part1-radial distribution systems. *IEEE Trans. Power Delivery*. 15, 486-493.
3. Dugan RC and McDermott TE (2002) Operating conflicts for distributed generation interconnected with utility distribution systems. *IEEE Industry Appl. Magazines*. 19-25.
4. Kauhaniemi K and Kumpulainen L (2004) Impact of distributed generation on the protection of distribution networks. *Developments in Power System Protection. 8<sup>th</sup> IEE Intl. Conf.* 1, 315 - 318.
5. Girgis A and Brahma S (2001) Effect of distributed generation on protective device coordination in distribution system. *Power Engineering, Large Engg. Systems Conf. (LESCOPE'01)*, 1, 115 - 119.
6. Doyle MT (2002) Reviewing the impacts of distributed generation on distribution system protection. *Power Engg. Soc. Summer Meeting. IEEE*. 1,103-105.