

Study of distance relays with fault resistance compensation for unbalanced systems

Hamid Asghari Rad and Mehrdad Ahmadi Kamarposhti*

Department of Electrical Engineering, Jouybar Branch, Islamic Azad University, Jouybar, Iran
m.ahmadi@jouybariau.ac.ir

Abstract

Fault resistance is a determinant quantity in distance relays. If this resistance is not considered it may cause wrong operation of relays. Moreover, unbalanced loads and non-symmetrical lines can affect a distance relay performance. In this paper we present a new algorithm to increase the accuracy and improve the efficiency of distance relays. The method proposed is based on phase coordination and utilizing from fault resistance estimation.

Keywords: Fault diagnosis, Fault resistance, Power system faults, Power system protection.

Introduction

In power systems, short circuits occur by agents such as broken insulators, lightning strikes, failure in equipments and even contact of trees and birds with electric facilities. Hence there is a need to design a protective system to prevent system from such failure, immediately eliminate the fault, and secure the system reliability. Distance relays, whether of the phase or ground type, is used for protection of transmission lines. Distance relays make a comparison between positive-sequence apparent impedance measured from one terminal line and performance characteristic of the relay for giving the command of interruption. The resistance at the point of short circuit produces a deviation in estimation of fault distance by distance relays. It is for this reason that in impedance faults the distance between the relay location and the location of short circuit is not necessarily proportional to the impedance observed by the relay. In symmetric short circuits, the fault generated by the point of short circuit is given by Eq. (1) (Horowitz and Phadke, 2006).

$$Z_A = \frac{E}{I} = Z_F + R_F \left[\frac{I_R}{I_S} + 1 \right] \quad (1)$$

In which Z_a is the measured apparent impedance, I and E are respectively the current and voltage of the current main phasor calculated at fault location, and Z_F is the impedance resistance of the line between the relay location and the location of short circuit, and R_F is the fault resistance. Fault resistance causes the distance relays not to operate inside the first protection zone (zone

1) which is shown in (Fig.1)

The way to overcome this problem is to compensate the fault resistance. There are many methods for proper operation of a relay inside the respective zone including square characteristic technique which depends on the angle between I_R and I_S (Ziegler, 2006). There are also other methods that are referred to in references (Xia *et al.*,2004; Erezzaghi & Crossley,2003; Waikar *et al.*,1994).

However, the restriction created due to the maximum capacity of the lines might threaten the relay performance in case of the occurrence of short circuits with high resistance. To overcome this problem, a number of suggestions have proposed for estimation of fault resistance, which still the performance of this method is limited to the balanced systems and transposed transmission lines (Filomena *al.*,2008).

This paper presents a new method for estimation of fault resistance based on phase coordination. This method is useful for balanced and unbalanced lines, and transposed and non-transposed lines.

Ground distance relays with fault-resistance compensation

In this section we present an algorithm for phase to ground faults, using phase coordination and considering the resistance of fault location.

Considering (Fig.2) which indicates a single phase, phase to ground fault, the voltage of fault location is given by Eq. (2)

$$V_{Fa} = V_{Sa} - x \cdot [Z_a] \cdot [I_S] \quad (2)$$

In which V_{Sa} is the voltage of phase a, at the point

Fig.1. Improper operation of distance relay due to fault resistance

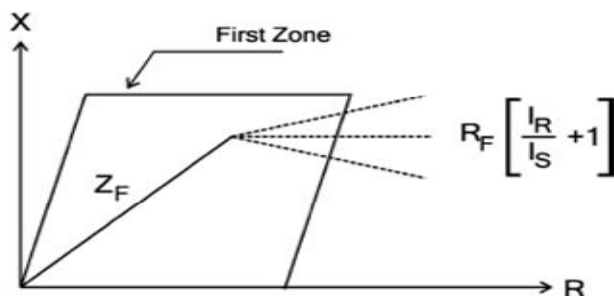
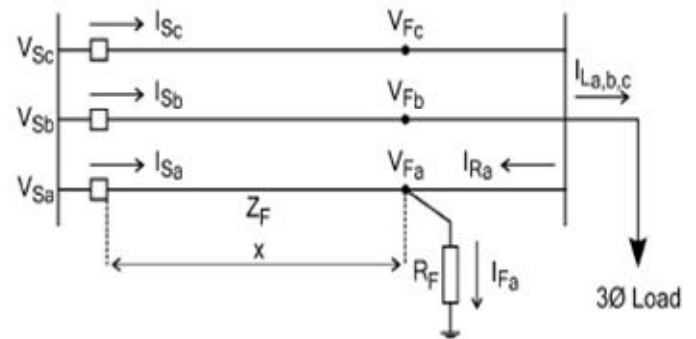

Fig.2. Short circuited transmission line



where the relay is located, $[Z_A]$ is the impedance vector of phase a, and x denotes the distance between the relay location and the fault location, and I_S is the matrix for current vector. By expanding Eq. (2), we have Eq. (3)

$$V_{Fa} = V_{Sa} - x.(Z_{aa}.I_{Sa} + Z_{ab}.I_{Sb} + Z_{ac}.I_{Sc}) \quad (3)$$

$$V_{Fa} = R_F.I_{Fa} \quad (4)$$

R_F is the resistance of the fault location, and will have the fault current, I_{Fa} in the following equation.

$$I_{Fa} = I_{Sa} + I_{Ra} \quad (5)$$

I_{Ra} is the fault current of phase a. Considering Eqs. (3)-(5), we have Eq. (6)

$$V_{Fa} = R_F.(I_{Ra} + I_{Sa}) - x.(Z_{aa}.I_{Sa} + Z_{ab}.I_{Sb} + Z_{ac}.I_{Sc}) \quad (6)$$

Apparent resistance at the point where the relay is located is given by Eq. (7)

$$Z_{map} = \frac{V_{Sa}}{I_{Sa}} \quad (7)$$

Using Eqs.(6) and (7), the measured apparent impedance Z_{map} is given by Eq. (8)

$$Z_{map} = x.[Z_{aa} + Z_{ab} \frac{I_{Sb}}{I_{Sa}} + Z_{ac} \frac{I_{Sc}}{I_{Sa}}] + R_F \cdot \left[1 + \frac{I_{Ra}}{I_{Sa}} \right] \quad (8)$$

The right hand side of Equation (8) shows the contribution of fault resistance to the measured apparent impedance. The first term in the right hand side of this equation represents the line impedance between the relay location and the fault location. Phase coordination method indicates that this impedance depends on three phase currents due to mutual interaction.

Taking into account that l is the total length of the line and P is the percents of line's length that must be protected, and $[Z]$ is the impedance matrix of the line, Eq. (8) may be rewritten as follows:

$$l.p.[Z_{aa} + Z_{ab} \frac{I_{Sb}}{I_{Sa}} + Z_{ac} \frac{I_{Sc}}{I_{Sa}}] = Z_{map} - R_F \cdot \left[1 + \frac{I_{Ra}}{I_{Sa}} \right] \quad (9)$$

During a fault the left hand side of Eq. (9) is determined by measuring the current and relay adjustments, and then the measured impedance Z_{map} , is estimated by short circuit fault estimation for the correct command of fault.

Estimating the resistance of fault location via phase coordination method

Mathematical calculations

Considering Figure 2 which shows a short-circuit in phase A, the measured voltages is given by Eq. (10)

$$\begin{bmatrix} V_{Sa} \\ V_{Sb} \\ V_{Sc} \end{bmatrix} = x \cdot \begin{bmatrix} Z_{aa} & Z_{ab} & Z_{ac} \\ Z_{ba} & Z_{bb} & Z_{bc} \\ Z_{ca} & Z_{cb} & Z_{cc} \end{bmatrix} \cdot \begin{bmatrix} I_{Sa} \\ I_{Sb} \\ I_{Sc} \end{bmatrix} + \begin{bmatrix} V_{Fa} \\ V_{Fb} \\ V_{Fc} \end{bmatrix} \quad (10)$$

In which x is the distance between the relay location and the fault location, Z_m is self impedance of phase m , and Z_{mn} is mutual impedance between phases m and n , and $V_{F,a,b,c}$ are the voltages at the point of short circuit. For short circuit at point A, the faulted phase voltages are

given by Eq. (11)

$$V_{Sa} = V_{Fa} - x.(Z_{aa}.I_{Sa} + Z_{ab}.I_{Sb} + Z_{ac}.I_{Sc}) \quad (11)$$

Eq. (11) may be resolved into two real and imaginary parts which are given by Eqs. (12) and (13)

$$V_{Sar} = x.M_1 + R_F.I_{Far} \quad (12)$$

$$V_{Sai} = x.M_2 + R_F.I_{Fai} \quad (13)$$

$$M_1 = Z_{aar}.I_{Sar} - Z_{aai}.I_{Sai} + Z_{abr}.I_{Sbr} - Z_{abi}.I_{Sbi} + Z_{acr}.I_{Scr} - Z_{aci}.I_{Sbi} \quad (14)$$

$$M_2 = Z_{aar}.I_{Sai} - Z_{aai}.I_{Sar} + Z_{abr}.I_{Sbi} - Z_{abi}.I_{Sbr} + Z_{acr}.I_{Sci} + Z_{aci}.I_{Sbr} \quad (15)$$

Now Eqs. (12) and (13) may be rewritten in the matrix form of Eq. (16)

$$\begin{bmatrix} V_{Sar} \\ V_{Sai} \end{bmatrix} = \begin{bmatrix} M_1 & I_{Far} \\ M_2 & I_{Fai} \end{bmatrix} \begin{bmatrix} x \\ R_F \end{bmatrix} \quad (16)$$

$$\begin{bmatrix} x \\ R_F \end{bmatrix} = \frac{1}{M_1 I_{Fai} - M_2 I_{Far}} \begin{bmatrix} I_{Fai} & -I_{Far} \\ -M_2 & M_1 \end{bmatrix} \begin{bmatrix} V_{Sar} \\ V_{Sai} \end{bmatrix} \quad (17)$$

From Eq. (17) the value of fault resistance and the distance from the fault location is obtained by Eqs. (18) and (19)

$$x = \frac{I_{Fai} V_{Sar} - I_{Far} V_{Sai}}{M_1 I_{Fai} - M_2 I_{Far}} \quad (18)$$

$$R_F = \frac{-M_2 V_{Sar} + M_1 V_{Sai}}{M_1 I_{Fai} - M_2 I_{Far}} \quad (19)$$

According to Eqs. (18) and (19), we can obtain the fault resistance and the fault distance from system parameters, fault current and voltages at the two ends of the line.

The process of fault current estimation

The only unknown variable contained in Eq. (19) is the phasor fault current $I_{Far,i}$.

Referring to Eq. (2), fault current can be obtained by Eq. (20).

$$I_{Fa} = I_{Sa} + I_{Ra} = I_{Sa} - I_{La} \quad (20)$$

In which I_{La} is the load current associated with phase a. Taking into account that the load current at the time of the occurrence of short circuit is different from the load current before the occurrence of short circuit due to voltage drop and dynamical effects that are produced during a fault, so a method is used to estimate the load current during a fault.

Step 1) we assume that load current I_{La} during a fault is the same as the load current before the fault

Step 2) the fault current is calculated using Eq. (20)

Step 3) fault location and fault resistance are estimated by Eqs. (18) and (19)

Step 4) the voltage at the fault location is estimated by Eq. (21)

$$\begin{bmatrix} V_{Fa} \\ V_{Fb} \\ V_{Fc} \end{bmatrix} = \begin{bmatrix} V_{Sa} \\ V_{Sb} \\ V_{Sc} \end{bmatrix} - x \cdot \begin{bmatrix} Z_{aa} & Z_{ab} & Z_{ac} \\ Z_{ba} & Z_{bb} & Z_{bc} \\ Z_{ca} & Z_{cb} & Z_{cc} \end{bmatrix} \begin{bmatrix} I_{Sa} \\ I_{Sb} \\ I_{Sc} \end{bmatrix} \quad (21)$$

Step 5) using the voltages at the fault location, the load current I_{La} is calculated again in Eqs. (22) and (23).

$$I_{La} = [Y_{aa} \ Y_{ab} \ Y_{ac}] [V_{Fa} \ V_{Fb} \ V_{Fc}]^T \quad (22)$$

$$Y_{mn} = [(l-x)Z_{mn} + Z_{Lmn}]^{-1} \quad (23)$$

In which Z_{mn} is the line impedance (self and mutual) between phases m and n, and Z_{Lmn} is the Load impedance (self and mutual) between phases m and n.

Step 6) using Eq. (24), the convergence of R_F is evaluated.

$$|R_F(n) - R_F(n-1)| < \delta \quad (24)$$

Step 7) if the value of resistance R_F converge, interrupt the algorithm and go back to step (2)

The output of this algorithm is determination of fault resistance R_F and load current $I_{La} = -I_{Ra}$. These values are used in Eq. (9)

Case study

To evaluate the proposed method performance, several short circuits were simulated using (ZMTP) software. One-line diagram of the understudied system is shown in (Fig.3)

Fig.3. The three-phase power system that was used in case study

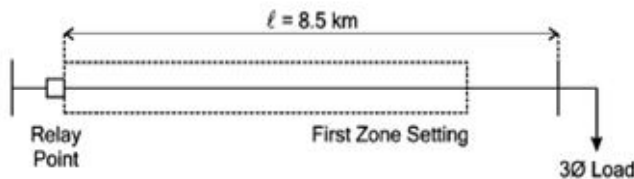

The length of the understudied line is 8.5 Km and its frequency is 60 Hz and the impedance matrix is according to Eq. (25).

$$Z_{line} = \begin{bmatrix} 0.297 + j0.1858 & 0.1018 - j0.0204 & 0.0772 - j0.038 \\ 0.1018 - j0.0204 & 0.2806 - j0.1674 & 0.1018 - j0.0204 \\ 0.0772 - j0.038 & 0.1018 - j0.0204 & 0.297 + j0.1858 \end{bmatrix} \Omega/km \quad (25)$$

To analyses the results obtained by the experiments, characteristic admittance of a distance relay with 85% first zone performance we used the line total impedance (7225 m away from the relay location). Voltages and currents at the point of the relay location are measured using the sample amount equal to 192 samples per second and then using the Fourier half-wave filter. Loads are balanced and are given for each of the phases of the system by the relation $Z_{load} = 32.4 + j10.8\Omega$. Apparent impedance calculated using the proposed algorithm is represented by continues line and broken lines represent the apparent impedance observed by the ground relay

and obtained by the relation $Z_{apparent} = \frac{E_a}{I_a}$. In this

Equation m is compensation factor, I_0 is the measured zero-sequence current, Z_0 and Z_1 are given by Eqs. (26)

and (27).

$$Z_{a0} = \frac{1}{3} \cdot (Z_{aa} + Z_{bb} + Z_{cc}) \quad (26)$$

$$Z_{ab0} = \frac{1}{3} \cdot (Z_{ab} + Z_{bc} + Z_{ca}) \quad (27)$$

In Fig. 4 and 5, faults occurs with a $R_F=0.750\Omega$ at 4 km, 7.5 km away from the relay location.

Distance relays for which the presented algorithm was used, have operated properly. In Figure 4 the conventional relay (short circuit occurred inside zone1) has not operated properly. In Figure 5 which short circuit occurred outside the number 1 protection zone, the

Fig.4. The relay performance during the fault of phase A, $R_F=750\Omega$ and $x=4km$ (internal fault)

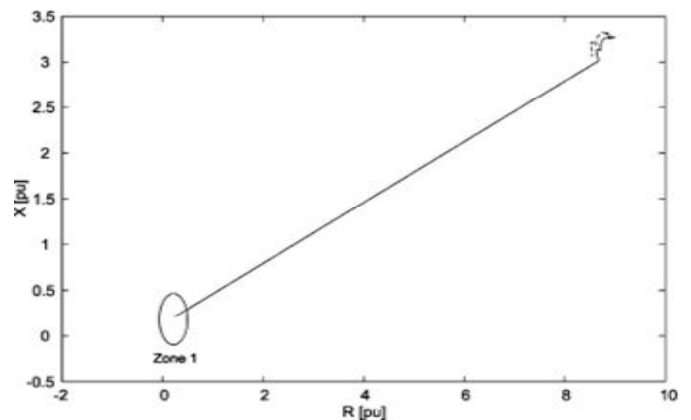
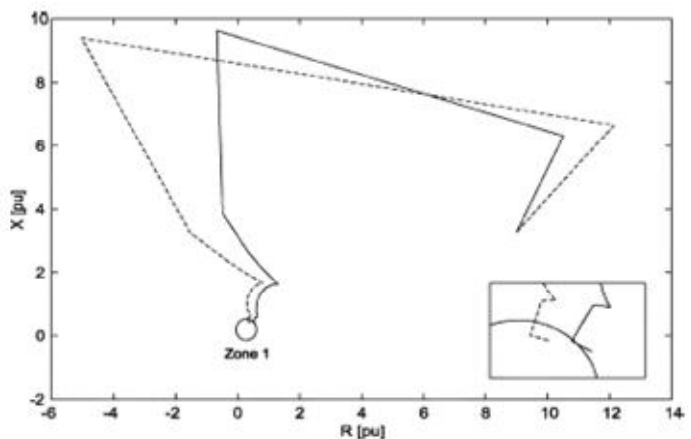

Fig.5. The relay performance during the fault of phase A, $R_F=750\Omega$ and $x=7.5km$ (external fault)



conventional relay has not operated properly, because the conventional relay has operated inside zone 1 due to the entrance of impedance, but for the relay for which the proposed algorithm was used, since it operates, based on the convergence of the algorithm, according to Eq. (24), it has not operated upon entering to the respective zone, but instead operates properly outside the respective zone as soon as the convergence of Eq. (24) was met.

In the second group, when we have unbalanced loads $Z_{load,a} = 32.4 + j10.8\Omega$ and $Z_{load,b} = 25.92 + j88.64\Omega$ and $Z_{load,c} = 29.16 + j9.72\Omega$ simulations has shown in Fig.6 which is similar to Fig. 5, except that its loads are unbalanced.

Fig.6. The relay performance during the fault of phase A with unbalanced load, $R_f=750\Omega$ and $x=7.5\text{km}$ (external fault)

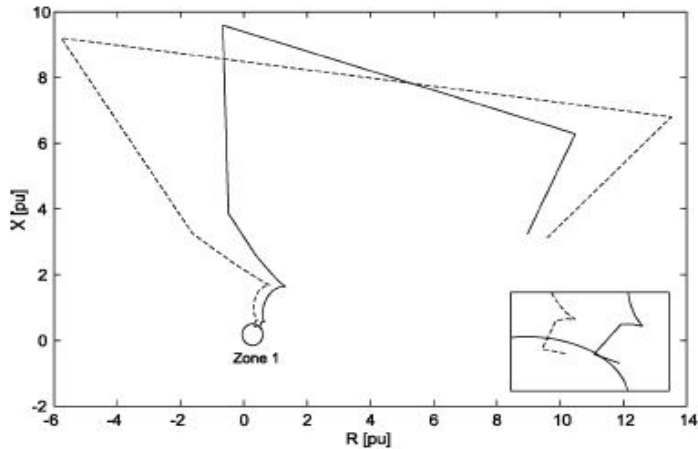

The conventional relay has not operated properly, but the relay for which the proposed algorithm was used, has operate properly and outside the protection zone since it gives the command of interruption when the algorithm reaches to convergence.

Conclusion

In this article, a new numerical algorithm was presented for estimation of fault resistance which is based on phase coordination method. This method is useful for balanced and unbalanced systems including systems with transposed lines and balanced and unbalanced loads. The results suggest that the proposed method is resistant to fault resistance or fault location.

References

1. Erezzaghi M and Crossley P (2003) The effect of high resistance faults on a distance relay. *IEEE Power Engg. Soc. General Meeting*. 4,13-17.
2. Filomena A D, Salim R H, Resener M, Bretas A S (2008) Ground distance relaying with fault-resistance compensation for unbalanced system. *IEEE Trans.Power Del.* pp: 23(3), 1319-1326.
3. Horowitz S H and Phadke A G (2006) Power system relaying, Third zone revisited. *IEEE Trans. Power Del.* 21(1), 23-29
4. Waikar DL, Elangovan S and Liew A C (1994) Fault impedance estimation algorithm for digital distance relaying. *IEEE Trans. Power Del.* 9(3), 1375-1383.
5. Xia Y Q, David A K and Li K K (2004) High-resistance faults on a multi-terminal line: analysis, simulated studies and an adaptive distance relaying scheme. *IEEE Trance. Power Del.* 9(1), 492-500.
6. Ziegler G (2006) Numerical distance protection: principles and applications, Erlagen, Germany: Publicis Corporate Publ., B.U.M. Siemens.