

Controller parameters design of doubly feed induction generator using Particle Swarm Optimization

Hasan Fayazi Boroujeni^{*}, Meysam Eghtedari, Ahmad Memaripour and Elahe Behzadipour

Department of Electrical Engineering, Boroujen Branch, Islamic Azad University, Boroujen, Iran
 hasanfayaziboroujeni@gmail.com ; meysameghtedari@yahoo.com; memarpor@yahoo.com;
 e.behzadipour@yahoo.com

Abstract

The integration of wind farms into the electricity grid has become an important challenge for the utilization and control of electric power systems, because of the fluctuating and intermittent behavior of wind power generation. Doubly fed induction generators (DFIG) are commonly used wind turbine generators (WTG) in electricity networks. In DFIG there are three control loops which should be implemented in order to appropriate performance of WTG. These control loops are pitch angle control, rotor speed control and voltage control. In this paper a unified scheme is used to adjust these controllers in the same time. Particle Swarm Optimization (PSO) is used to adjustment the proposed controllers. The results of wind power on the system performance are compared with a conventional thermal power plant.

Keywords: Wind Turbine Generators; Doubly Fed Induction Generators; Pitch Angle Control; Multi Machine Electric Power System; Particle Swarm Optimization.

Introduction

Wind turbines generators (WTGs) are usually controlled to generate maximum electrical power from wind under normal wind conditions. However, because of the variations of the wind speed, the generated electrical power of a WTG is usually fluctuated. Currently, wind energy only provides about 1%-2% of the U.S.'s electricity supply. At such a penetration level, it is not necessary to require WTGs to participate in automatic generation control, unit commitment, or frequency regulation.

In order to meet power needs, taking into account economical and environmental factors, wind energy conversion is gradually gaining interest as a suitable source of renewable energy. The electromagnetic conversion is usually achieved by induction machines or synchronous and permanent magnet generators. Squirrel cage induction generators are widely used because of their lower cost, reliability, construction and simplicity of

maintenance (Heier, 1998). But when it is directly connected to a power network, which imposes the frequency, the speed must be set to a constant value by a mechanical device on the wind turbine. Then, for a high value of wind speed, the totality of the theoretical power cannot be extracted. To overcome this problem, a converter, which must be dimensioned for the totality of the power exchanged, can be placed between the stator and the network. In order to enable variable speed operations with a lower rated power converter, doubly-fed induction generator (DFIG) can be used as shown on Fig.1.

The stator is directly connected to the grid and the rotor is fed to magnetize the machine. Control of electrical power exchanged between the stator of the DFIG and the power network by controlling independently the torque (consequently the active power) and the reactive power is an important issue in DFIG utilization (Xu & Cheng, 1995). Several investigations have been developed in this direction using converters and classical proportional-integral regulators (Yamamoto & Motoyoshi, 1991; Rifai & Ortmeier, 1993; Hopfensperger *et al.*, 2000).

In this paper a unified scheme is used to adjust DFIG controllers in same time. Particle Swarm Optimization (PSO) (Mehdi Nikzad *et al.*, 2011; Sayed Mojtaba Shirvani Boroujeni *et al.*, 2011) is used to adjustment the proposed controllers. The results of wind power on the system performance are compared with a conventional thermal power plant.

Mathematical model of the DFIG

For a doubly fed induction machine, the Concordia and Park transformation's application to the traditional a,b,c model allows to write a dynamic model in a d-q reference frame as follows:

Fig.1. Variable speed wind turbine with doubly fed induction generator

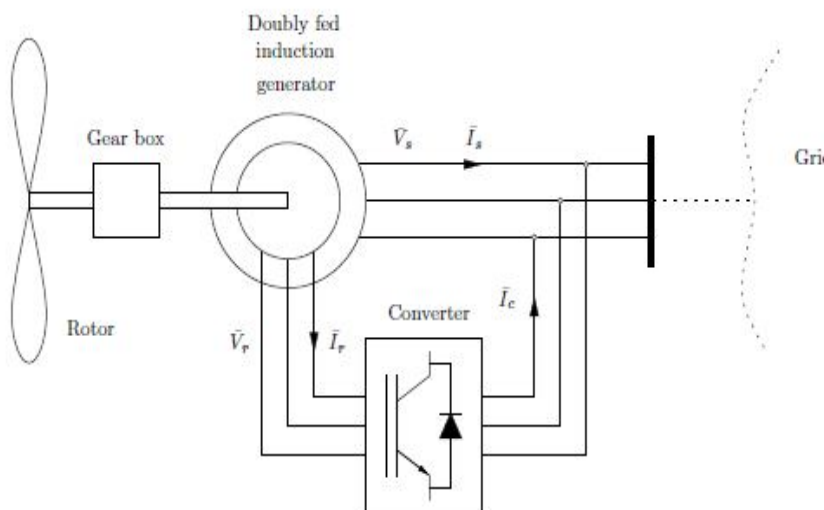

$$\begin{cases}
 V_{ds} = R_s I_{ds} + \frac{d\Psi_{ds}}{dt} - \theta_s \Psi_{qs} \\
 V_{qs} = R_s I_{qs} + \frac{d\Psi_{qs}}{dt} + \theta_s \Psi_{ds} \\
 V_{dr} = R_r I_{dr} + \frac{d\Psi_{dr}}{dt} - \theta_r \Psi_{qr} \\
 V_{qr} = R_r I_{qr} + \frac{d\Psi_{qr}}{dt} + \theta_r \Psi_{dr} \\
 \Psi_{ds} = L_s I_{ds} + M I_{dr} \\
 \Psi_{qs} = L_s I_{qs} + M I_{qr} \\
 \Psi_{dr} = L_r I_{dr} + M I_{ds} \\
 \Psi_{qr} = L_r I_{qr} + M I_{qs} \\
 \Gamma_m = \Gamma_e + J \frac{d\Omega}{dt} + f\Omega \\
 \Gamma_e = -P \frac{M}{L_s} (\Psi_{qs} I_{dr} - \Psi_{ds} I_{qr})
 \end{cases} \quad (1)$$

DFIG control

Fig.2. Rotor speed control scheme

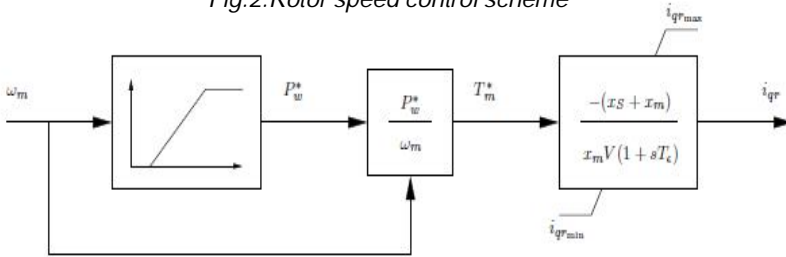

Fig.3. Voltage control scheme

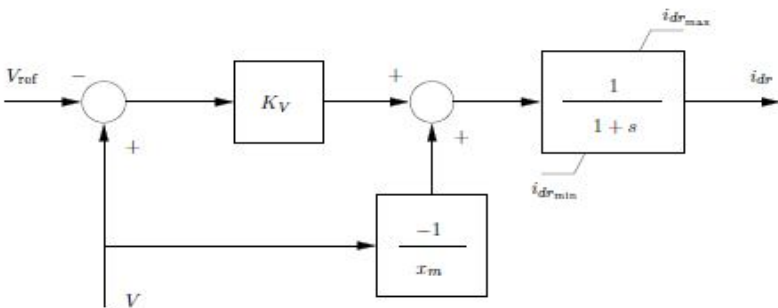
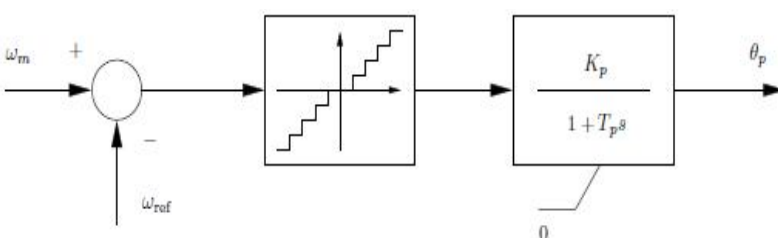

Fig.4. Pitch angle control scheme



In DFIG there are three control loops which should be implemented in order to appropriate performance of wind farm. These control loops are pitch angle control, rotor speed control and voltage control. These control schemes are thoroughly explained in Fig.2-4. In this paper PSO is used to adjust proposed controllers.

Particle swarm optimization

PSO was formulated by Edward and Kennedy in 1995. The thought process behind the algorithm was inspired by the social behavior of animals, such as bird flocking or fish schooling. PSO is similar to the continuous GA in that it begins with a random population matrix. Unlike the GA, PSO has no evolution operators such as crossover and mutation. The rows in the matrix are called particles (same as the GA chromosome). They contain the variable values and are not binary encoded. Each particle moves about the cost surface with a velocity. The particles update their velocities and positions based on the local and global best solutions as shown in (2) and (3):

$$\begin{aligned}
 V_{m,n}^{new} &= W \times V_{m,n}^{old} + \Gamma_1 \times r_1 \times (P_{m,n}^{local\ best} - P_{m,n}^{old}) \\
 &+ \Gamma_2 \times r_2 \times (P_{m,n}^{global\ best} - P_{m,n}^{old}) \quad (2)
 \end{aligned}$$

$$P_{m,n}^{new} = P_{m,n}^{old} + \Gamma V_{m,n}^{new} \quad (3)$$

Where:

$V_{m,n}$ = particle velocity

$P_{m,n}$ = particle variables

W = inertia weight

r_1, r_2 = independent uniform random numbers

Γ_1, Γ_2 = learning factors

$P_{m,n}^{local\ best}$ = best local solution

$P_{m,n}^{global\ best}$ = best global solution

The PSO algorithm updates the velocity vector for each particle then adds that velocity to the particle position or values. Velocity updates are influenced by both the best global solution associated with the lowest cost ever found by a particle and the best local solution associated with the lowest cost in the present population. If the best local solution has a cost less than the cost of the current global solution, then the best local solution replaces the best global solution. The particle velocity is reminiscent of local minimizes that use derivative information, because velocity is the derivative of position. The advantages of PSO are that it is easy to implement and there are few parameters to adjust. The PSO is able to tackle tough cost functions with many local minima (Randy & Sue, 2004).

Illustrative test case

In order to evaluate the effect of WTG on the system performance, a multi machine electric power system which is IEEE 14 bus test system is considered as case study (Milano, 2010). In the proposed test system two following cases

Fig.5.EEE 14-bus test system

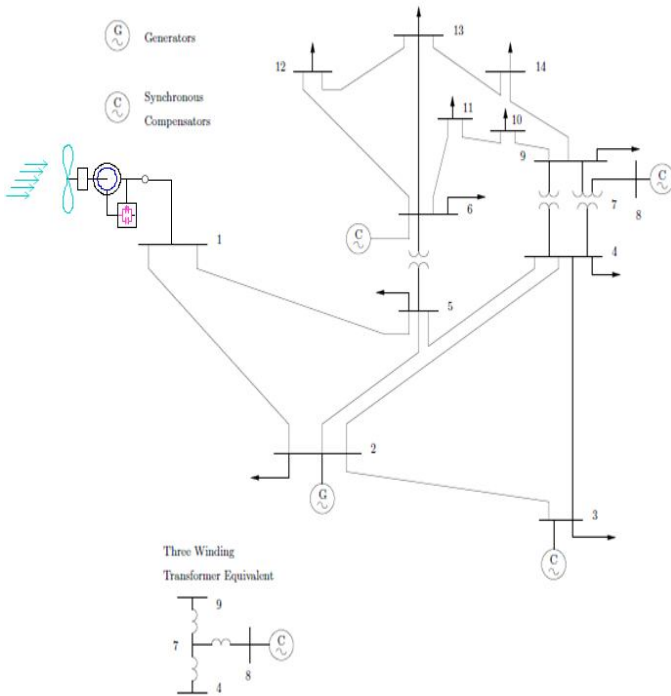

are considered:

Case 1: power generator at bus 1 is a thermal power plant

Case 2: power generator at bus 1 is a wind turbine power plant

Both the cases are simulated and compared under disturbance. Fig.5 shows the proposed test system with a WTG installed in bus 1. Also in this paper the wind speed is modeled as Weibull Distribution (Milano, 2010).

Controllers adjustment using PSO

In this section the parameters of the proposed controllers are tuned using PSO. In optimization methods, the first step is to define a performance index for optimal search. In this study the performance index is considered as (4). In fact, the performance index is the Integral of the Time multiplied Absolute value of the Error (ITAE).

$$ITAE = \int_0^t t|\Delta\omega_1|dt + \int_0^t t|\Delta\omega_2|dt + \int_0^t t|\Delta\omega_3|dt + \int_0^t t|\Delta\omega_4|dt + \int_0^t t|\Delta\omega_5|dt \tag{4}$$

It is clear to understand that the controller with lower ITAE is better than the other controllers. To compute the optimum parameter values, a three phase short circuit is assumed at bus 4 and the performance index is minimized using PSO.

It should be noted that PSO algorithm is run several times and then optimal set of parameters is selected. The optimum values parameters are obtained using PSO and summarized in Table.1.

Fig.6.Speed of generator 1 Solid (wind power plant at bus 1); Dashed (thermal power plant at bus 1)

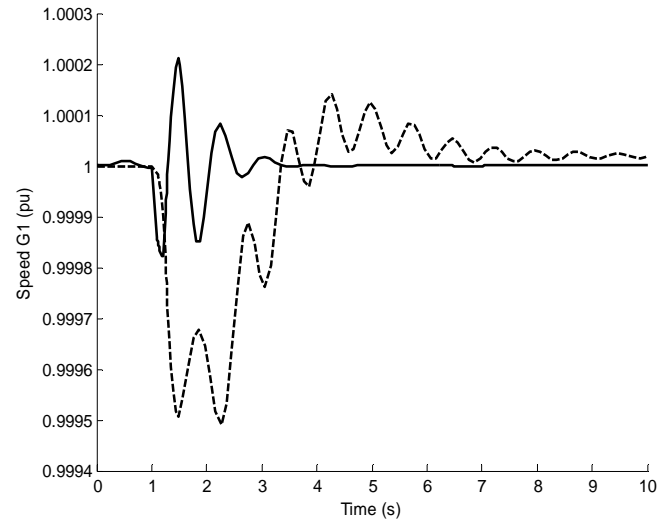

Fig. 7.Speed of generator 2 Solid (wind power plant at bus 1); Dashed (thermal power plant at bus 1)

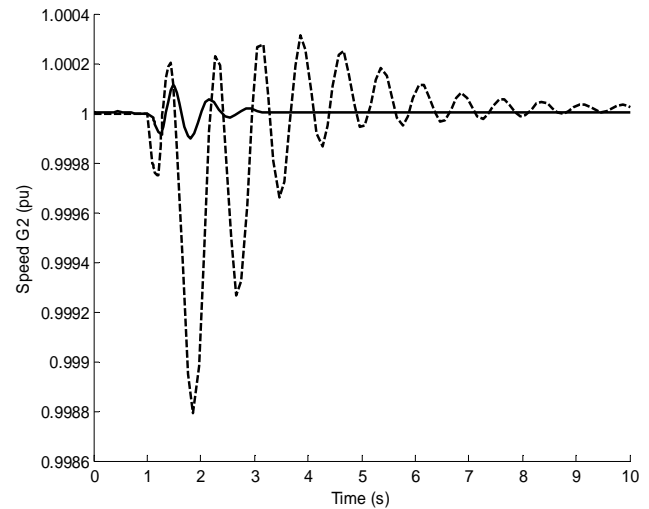

Fig.8.Speed of generator 3 Solid (wind power plant at bus 1); Dashed (thermal power plant at bus 1)

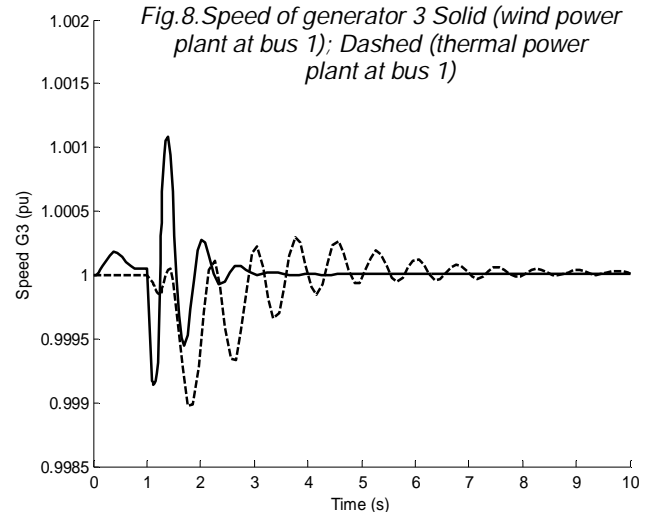

Table1.Optimum values of controllers

Pitch angle gain	12.72
Pitch angle time constant	0.03
Voltage control gain	69.91
Power control time constant	0.015

Results and discussions

The simulation results are carried out on the proposed test system with both the cases. Fig.6-10 show the results following a 12 cycle three phase short circuit is assumed at bus 14. It is clearly seen that WTG has a great effect on the system stability and increasing damping of oscillations. With WTG, in all figures the oscillations are damped out successfully and the transient

Fig.9. Speed of generator 4 Solid (wind power plant at bus 1); Dashed (thermal power plant at bus 1)

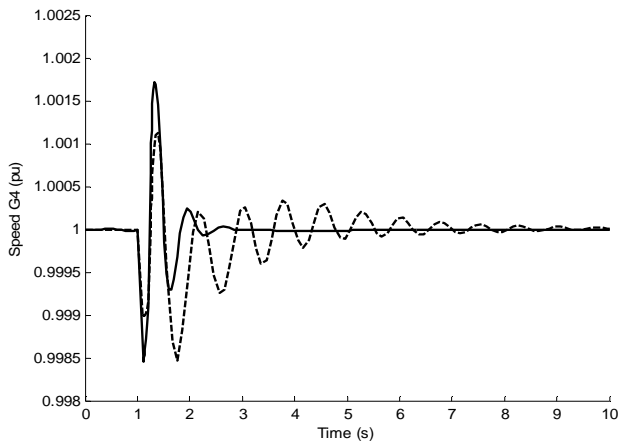
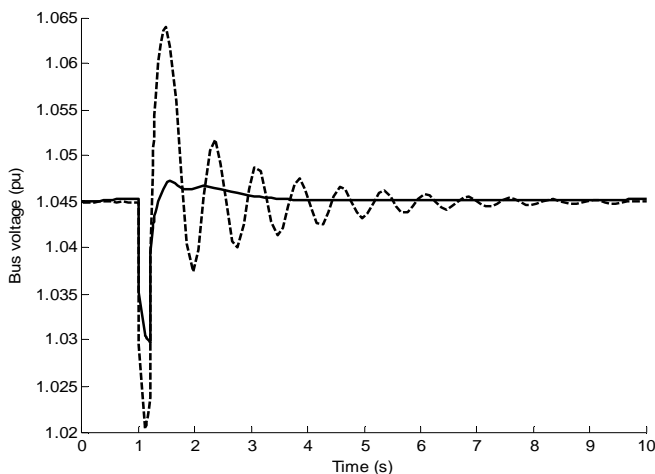

Fig.10. voltage of bus 2 Solid (wind power plant at bus 1); Dashed (thermal power plant at bus 1)



and dynamic stability margin of the system in increased. Also, voltage of bus 2 is demonstrated in Fig.10. It is clearly seen that WTG not only has a great effect on system stability but also has a positive effect on the voltage of bus.

Conclusion

A unified tuning of DFIG controllers successfully carried out in this paper. PSO used to adjust the DFIC controllers. The proposed DFIG was compared with conventional generators in thermal power plants. It showed that DFIG has a great effect on the system stability and performance. DFIG also successfully controlled the voltage. The paper showed that utilization of DFIG not only is suitable from view of energy and environmental effects, but also is appropriate from view of system stability and performance.

References

1. Heier S (1998) Grid integration of wind energy conversion systems. John Wiley & Sons Ltd. England.
2. Hopfensperger B, Atkinson DJ and Lakin RA (2000) Stator-flux-oriented control of a doubly fed induction machine with and without position encoder. *IEE Proc. Electrical Power Appl.* 147 (4), 241-250.
3. Mehdi Nikzad, Shoorangiz Shams Shamsabad Farahani, Mohammad Bigdeli Tabar, Mehdi Ghasemi Naraghi and Ali Javadian (2011) Adjustment of PSS in a multi machine power system based on particle swarm optimization technique. *Indian J.Sci.Technol.* 4 (8), 876-880. Domain site: <http://www.indjst.org>.
4. Milano F (2010) Power system analysis toolbox. version 2.1.6.
5. Randy LH and Sue EH (2004) Practical Genetic Algorithms, Second Edition. John Wiley & Sons. pp: 51-65.
6. Sayed Mojtaba Shirvani Boroujeni, Reza Hemmati, Hamideh Delafkar and Amin Safarnezhad Boroujeni (2011) Optimal PID power system stabilizer tuning based on particle swarm optimization. *Indian J.Sci.Technol.* 4 (4), 379-383. Domain site: <http://www.indjst.org>.
7. Xu L and Cheng W (1995) Torque and reactive power control of a doubly-fed induction machine by position sensorless scheme. *IEEE Transact. on Industry Appl.* 31(3), 636- 642.
8. Yamamoto M and Motoyoshi O (1991) Active and reactive power control for doubly-fed wound rotor induction generator. *IEEE Transact. on Power Electronics.* 6(4), 624-629.