

## Better moisture control in coke manufacturing- a case study

Sanjyot S. Borker and Prabir Kumar Bandyopadhyay\*  
Goa Institute of Management, Ribandar, Goa-403006, India  
gauriborker@yahoo.co.in; prabir@gim.ac.in\*

### Abstract

The purpose of coke quenching is to quench the incandescent coke in the hot car using intense water sprays covering entire cross-section of the red hot coke bed and preventing it from burning, at the same time to obtain coke of uniform and minimum deviations in coke moisture. This case study presents a simple approach of developing a Standard Operating Procedure (SOP) to reduce the variation in moisture in Coke by analyzing past data and using Cause and Effect diagram and critically analyzing the contribution of different factors in introducing variation in moisture. The pre and post SOP implementation results are analyzed statistically to ensure that the difference in variance of moisture content is statistically significant. After implementing the action plan for one quarter, overwhelming results were noticed. The standard deviation of moisture on day to day basis has reduced from 2.5% to 1.0%.

**Keywords:** Quenching, Metallurgical coke, Blast furnace, non-recovery oven, Drain time.

### Introduction

In the integrated steel plants, coke handling system in coke plant is designed to provide a 'Just in time' supply of metallurgical coke to Blast furnaces. While the benefits of lower coke inventory, frequent quality checks and low handling losses are obvious (World Bank Group, 1998; Walker & Barkdoll, 2003), this 'Just in time' delivery posed numerous operating challenges pertaining to variation of coke moisture. The BF grade coke is directly supplied to the Pig Iron Plant administered by separate Strategic Business Units (SBU). The quantity supplied is accounted in terms of Dry Metric Tons (DMT) basis. The variation of moisture varies the coke charge rate in blast furnace affecting Blast furnace performance. Secondly, higher moisture in coke reduces the quantity supplied affecting Production quantity at coke plant. Due to the financial impact on both the SBUs, viz. Pig Iron Plant and Met Coke Division, it has become critical to control the variation in moisture level in the BF coke.

### A brief on non-recovery coke making

#### Background

Non-recovery Coke Plants are originally referred to as Beehive Ovens, again the coal is carbonized in large oven chambers. The carbonization process takes place from the top by radiant heat transfer and from the bottom by conduction of heat through the sole floor. Primary air

for combustion is introduced into the oven chamber through several ports located above the charge level in both pusher and coke side doors of the oven. Partially combusted gases exit the top chamber through "down comer" passages in the oven wall and enter the sole flue, thereby heating the sole of the oven. As shown in Fig.1. Combusted gases collect in a common tunnel and exit via a stack, which creates a natural draft in the oven. Since the by-products are not recovered, the process is called Non-Recovery coke making. When the waste gas exits into a waste heat recovery boiler, which converts excess heat into steam for power generation, the process is called Heat Recovery Coke making.

As the Non-Recovery ovens operate under negative pressure and at a temperature at which all potential pollutants break down into combustible compounds, this technique consumes the by-products, eliminating much of the air and water pollution. On other hand recovery ovens operate with positive pressure causing heavy pollution in the adjoining area and it is very difficult to manage recovery ovens with complicated by-product plant. Due to these reasons integrated steel industries in India focused their attention towards less complex and eco friendly Non-Recovery coke making technology.

#### Oven construction

The ovens are constructed using a few standard brick shapes, robust walls and arches, simply cast structural slabs, and easily gunned insulating barriers. This simplicity greatly increases construction productivity and quality of work. The coking chamber measures 2.7mts wide by 10.5mts long and accepts a 25 tons charge of coal. The crown of the coking chamber is constructed of high alumina bricks laid in a bonded arch with the peak located approximately 4.5 mts above the oven floor. The free board space above the bed allows volatile matter to be partially combusted to provide radiant heat for coking from the top down. Combustion air is added to the crown through dampers on the oven doors. The floor of the coking chamber is constructed of large extruded refractory shapes which have excellent

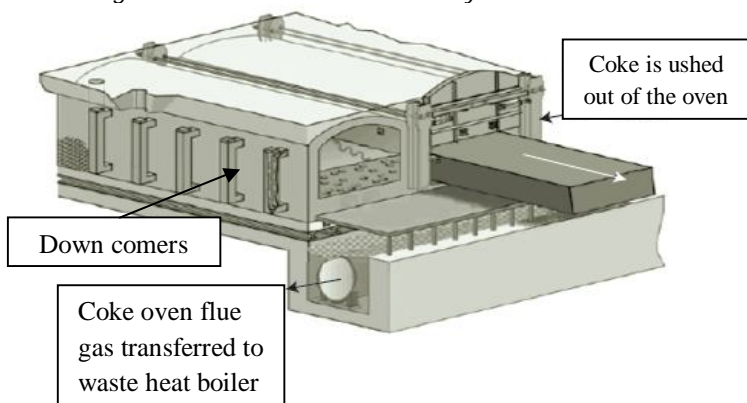
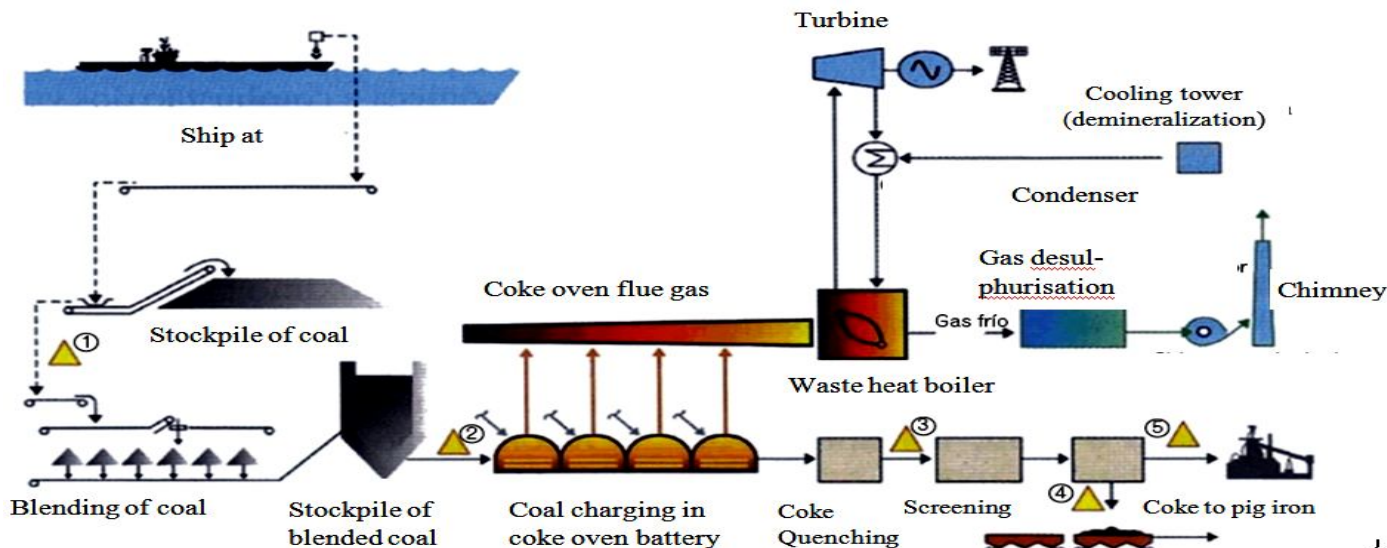

Fig. 1. Cross section of non-recovery Coke ovens

Fig. 2. Process flow diagram of Coke Plant



strength, thermal conductivity, abrasion resistance and heat transfer properties.

The oven walls separate the individual ovens (coking chambers) by vertical oriented flues down comers. The sole flues receive rich crown gas from down comers located within the walls. The sole flues provide a means of under firing so that heat is transferred through oven floor into the coal bed. The flue gas exits the sole flues via feeder flue in to a duct commonly connected to all the ovens called common flue. The draft of each oven can be regulated by refractory dampers located in the feeder flue before joining to the common flue. The common flue acts as a tunnel connecting ovens to the stack. The stack is in turn connected to the waste heat boilers for generating steam for supplying to the steam turbine for generating power.

**Coke oven process**

Coking coal is only raw material for coke making. Indian coking coals are having high ash content and coke of such coals is undesirable for blast furnaces. Low ash coking coals are available in many parts of the world which are largely used for making metallurgical coke all over the world. The coking coal in present coke plant is always imported. The coal is brought by ship at the port and then is hauled by the barges to the plant site. The coal is then transported by trucks and is stockpiled in the coal yard. Coal during processing is blended and crushed to < 3 mm size in an impact type coal crusher and then is stockpiled in silos. Same blended coal is retrieved and charged in the oven scheduled for charging. Refer Fig.2 for process flow diagram of coke plant.

Coking starts by means of heat retained in the brickwork from the previous coal charge. The evolving volatiles are mixed with air drawn (Primary air) into oven and are combusted. The oven dome radiates heat to coal mass. The heat of the combusted volatiles passes through the downcomers in the side walls into underflues.

Additional air (Secondary air) is input from the lower sides of the oven to assist in providing heat from the bottom of coal charge. Coking proceeds from the top of the charge in the direction of oven floor and also from the bottom of oven to the center of the coal mass. The coking cycle completes when the volatiles in the coal are exhausted. Coke so obtained is then pushed out of the oven and this hot coke is quenched at quench tower. The coke is screened for segregating different fractions of coke and is sent to desired location.

Complete combustion of the escaping hydrocarbons is achieved by providing (Tertiary air) in the common flue where the flue gas from individual ovens of each battery of ovens is drawn. The hot gas is drawn by induced draft fan through a waste heat boiler. The heat of the coke oven flue gas is taken out in the boiler and rest gas is let out after the process of desulphurization.

**Coke quenching operation**

The purpose of coke quenching tower is to quench red-hot glowing coke in the quenching car by intense water sprays, preventing it from getting burnt out. As shown in Fig.3. This operation unfortunately leaves some residual water in the quenched coke. The quenching process is designed to produce coke with least amount of water. This means that the quenched coke will still be

Fig. 3. Coke from oven & quenching operation

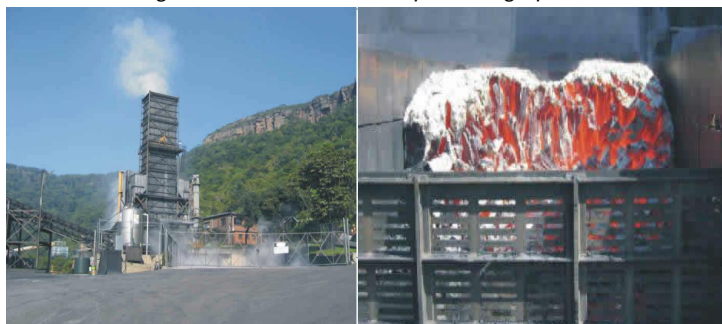

warm enough to evaporate the residual water left in the quenching process, leaving the coke as dry as possible. It is common practice to keep the temperature of quenched coke ranging 185 to 250 deg C. The quenching also has been so effective that the coke does not burn (the combustion temperature of coke being 400oC). On the other hand, if the coke is not adequately quenched, then it needs further local quenching on the wharf to prevent any damage to the down stream conveyor belt.

A typical quenching tower is a box type structural framework with peripheral sheeting arrangement. The quench car carries red-hot coke and moves into this quenching tower (shown in schematic no 4). The quenching technology adopted is wet quenching with semi-flooded quenching system. In this case many nozzles are arranged such that each giving linear downward flow, yet covering the entire quench car. The water sprayed in the quenching car is not allowed to drain away creating a pool of water in the quenching car. The coke floats in the car and gets quenched more uniformly and instantly. The water used for quenching is recycled after settling in the breeze pond then stored in the plant water dam and is pumped back in the overhead tank of quenching tower (refer block diagram). The loss of water

due to evaporation is replenished by adding make-up water provided from rain water storage pit. The Block diagram shows the quenching water system.

In semi-flooded quenching large quantity of water is sprayed into the quenching car initially for a short period of time to create flooding up to certain height. The generated steam quenches the upper layer of coke in the quenching car partially to be followed by water quenching. Quick flooding requires faster flow of water. Therefore additional nozzles are provided on the side of the quenching car at an angle of 45° with the horizontal. The side quenching operates for a few initial seconds during the process. After the lapse of predetermined time, the side queching stops and top quenching starts which creates a laminar flow of water to permit full quenching of coke for a specified time. The total quenching time is kept approximately 100 seconds as per basic design, but can be adjusted as per requirement. Thus this process achieves a uniform and full quenching of hot coke. The quenching water comes from fixed head overhead tank through motor operated quick acting butterfly valve. Each circuit is provided with two valves, so that the valve of each circuit can be kept in a standby position (Fig.4).

The need was felt to bring about improvement in the average levels of residual coke moisture achieved as well as keeping standard deviation low. A large number of improvement project taken in the past had helped in improving spraying water quality, the reliability of equipment, response time of valves etc. But these projects have not been able to make permanent impact in the intended objective. Therefore this work improvement project was chosen to address the long standing problem of variation of coke moisture which was affecting the smooth operation of both Coke plant and Pig iron plant.

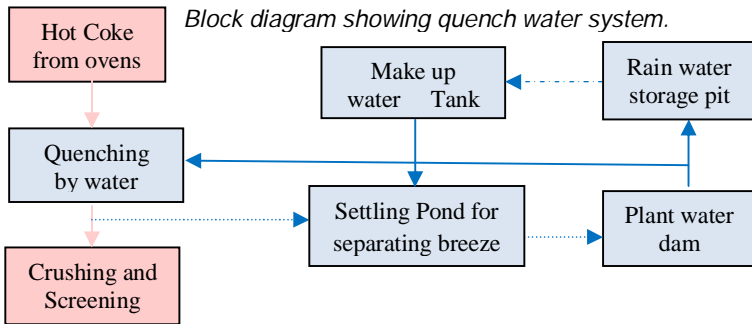
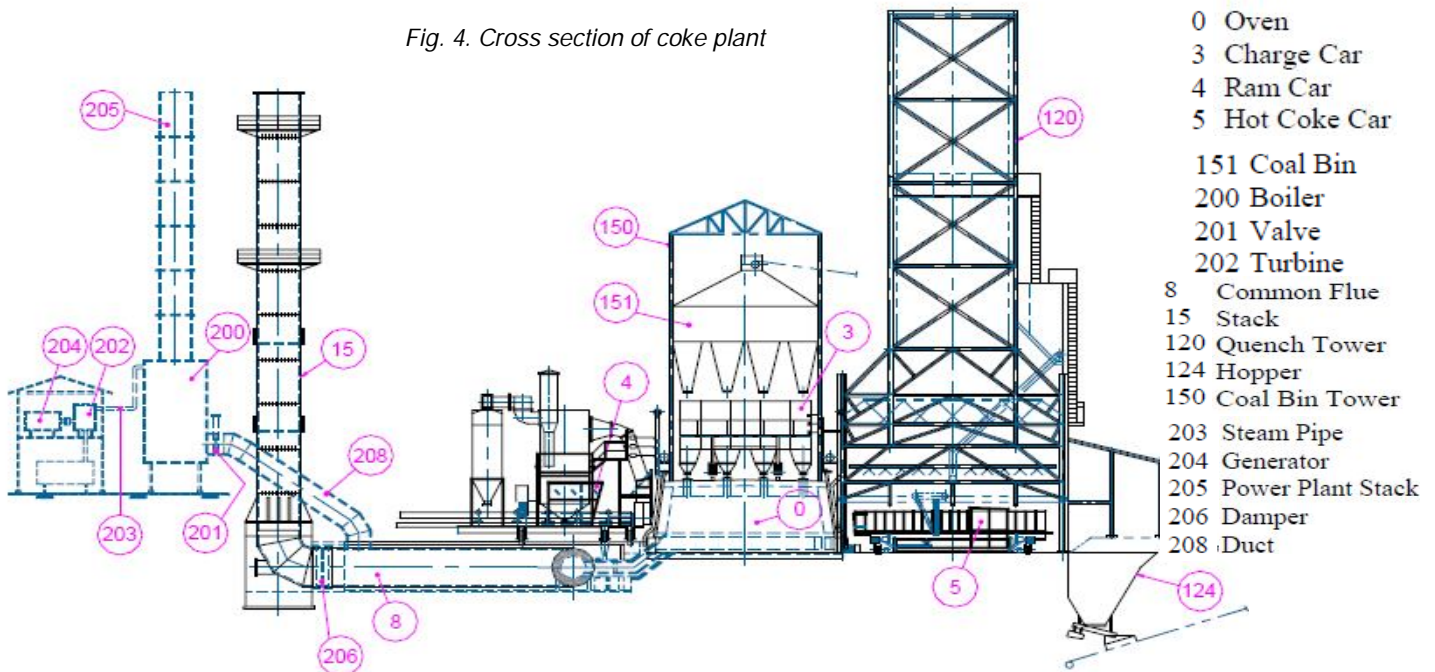

Fig. 4. Cross section of coke plant



**Problem identification**

At first daily coke moisture record for two years 2009 - 2010 was collected, with average 10 to 12 readings per day. Refer chart no.1. The reasons for variation in the coke moisture were identified and further analyzed through brain storming to arrive at probable causes for variation in moisture. This was further elaborated with the concept of Ishikawa (fishbone) diagram, shown in Fig.5.

Fig. 5. Ishikawa diagram - causes are identified for the problem of variation in moisture in coke

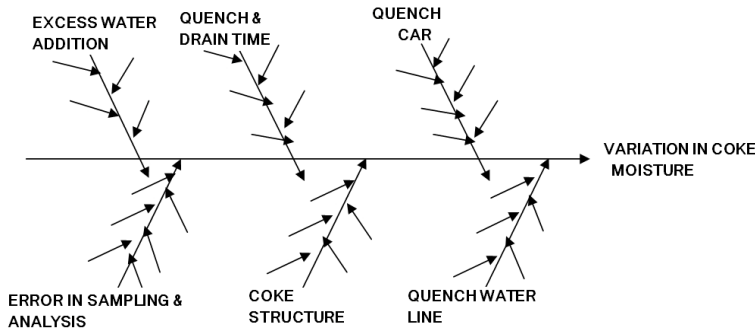

The above analysis triggered possible causes for increase in coke moisture. Some of the causes were obvious and easily implementable and they were taken up immediately. For other capital jobs, action plan was formulated, assigning responsibilities to engineers with target date. Each of these problems was solved in scheduled time and the coke moisture was monitored after each event.

**Problem solving approach**

Ishikawa diagrams (also called fishbone diagrams, cause-and-effect diagrams or Fishikawa) are diagrams that show the causes of a certain event. Common uses of the Ishikawa diagram are product design and quality defect prevention, to identify potential factors causing an overall effect. Each cause or reason for imperfection is a source of variation. Causes are usually grouped into major categories to identify these sources of variation. The categories typically include: i) People: Excessive water addition; ii) Methods: Regulation of Quench & Drain time; iii) Machines: Abnormalities in Hot car; iv) Materials: Coke structure, v) Measurements: Error in Coke Sampling & analysis, and vi) Environment: Fault in Quench water system. All these categories are analyzed below:

**Excessive water addition**

Positively there must be no water addition to the coke after quenching. In such case, the porous coke in the coke mass is likely to absorb water and increases the moisture level in coke. The areas wherein water is added to coke includes: a) Water addition through grit arrester sprays, b) Water running in adjacent coke hopper, c) Spot quenching, d) Dripping of water through quench nozzles, e) Water addition for dust suppression.

Further details are as follows:

**Grit arrester sprays:** During quenching operation dust particles escape along with the steam. To arrest these

dust particles, mesh is provided at the mid-point of quench tower. After each quenching, the grit arrester sprays are automatically actuated with a time lag so that sprayed water does not fall on the quenched coke.

**Adjacent coke hopper:** Due to space constraints, coke hopper is situated adjacent to the quench tower. In such case there is a possibility of overflowing of quench water over quench car end flaps and entering in the coke hopper. At this time any coke previously lying in the coke hopper gets in contact with water causing increase in moisture level.

**Spot quenching:** The coke passed on into the coke hopper must be immediately spread out on to the conveyor for evaporating. In case coke remains in the coke hopper for a long time, the hot pieces of coke catch fire. To quench this fire, water is sprayed through flexible hose. During such activity the neighboring coke gains moisture.

**Dripping through nozzles:** The problems may arise of wearing of quench valve seat after long run. In such case water starts dripping continuously through nozzles. Secondly in some coke plants the quench valves are kept at long distance from nozzles. After the valve is shut water from pipeline continues to fall on the coke. This adds moisture to the coke especially when staggered quenching cycle is in practiced.

**Dust suppression:** During transportation of coke on conveyors, a significant quantity of dust is generated specially at transfer points. In some coke plants dry fog system is enforced to curtail the dust. In case the spray nozzles are faulty, the water continuously drips over the coke causing it to gather moisture.

**Regulation of quench & drain time**

Uniformity in coke quenching is achieved by quick submerging the coke in a semi-flood quench system; keep the coke in contact with quench water for a specified time period and then drain out excess water as quickly as possible. This means, the water sprayed on the hot car with glowing hot coke, is not allowed to drain out instantly creating a pool of water in the car. The coke floats in the car, levels itself, and gets quenched more uniformly and instantly. The generated steam quenches the upper layers of coke in the quench car partially to be followed by water quenching.

The coke moving out of the oven is around 1000°C. This coke is quenched with heavy stream of fresh water to bring the temperature of coke below 200°C. The quench time is usually 90 to 120 seconds, depending upon the arrangement at quench tower such as capacity of quench water tank, water pipeline arrangement, type of quenching valve & nozzles, positioning of spray nozzles. The quenching is usually done in single stroke with intention to keep coke submerged in water for maximum time. Depending on the temperature of the coke at the downstream conveyor the quench time may be fine tuned. The quenching cycle may be staggered depending on the requisite of coke submergence in water or to meet

any design deficiencies. Once the quenching is over the water has to be drained quickly and the coke is sprayed for evaporation of moisture held on by the coke. The drain time usually kept between 45 to 60 seconds.

The problems envisaged during quenching are: a) Faulty operation of quench valve causing dripping of water through nozzles, b) Fault in electrical valve operating system causing missing of quench strokes, and c) Late opening and closing of quench valve due to its wear out.

#### *Abnormalities in Hot car*

The hot car has a tray and movable flap on one side. The side and base of hot car tray are made of liner plates of size 500x 500x50mm. The end flap has counter weight at bottom which holds water during quenching and later acts as base plate for transferring coke from hot car to coke hopper. Other side of hot car tray is guided by chain driven pusher blade which holds water during quenching and later pushes coke in the coke hopper. The main purpose of hot car tray is to hold sufficient quantity of water making hot coke to get submerged in the water. Once the quenching is over, the gaps between the liners on sides and bottom must allow quick drainage of water.

The problems foreseen at hot car are: a) Improper gaps in side and bottom liners, b) Large gaps at front and back end gates, c) Quench sprays not covering full tray, d) Improper alignment of quench car tray below nozzles, and e) Coke face not touching both side end gates.

#### *Coke structure*

Since high porosity material containing large pores, the gasification reaction at the stack region of Blast Furnace is controlled primarily by external pore diffusion process. Moreover, the strength of the coke material depends upon its structure and texture. The structure of the coke is the function of porosity and therefore for high strength metallurgical coke it is necessary to build up detailed knowledge of coke porous structure with the emphasis on its control.

Detailed information of porosity is as follows:

Porosity means the percentage ratio of volume of voids available in the coke to the summation of volume of coke and volume of the voids. Increase in the coke porosity means increase in the volume of voids in pores, decrease in volume of coke. This phenomenon will lead to more fragmentation of coke in the blast furnace. Increase in porosity lead to a) Higher surface area; b) Higher reaction rate; c) Lower gasification threshold temperature and d) Lower strength of coke.

The porosity in the coke can be controlled by taking following measures: a) Addition of low volatile coals in the coal blend, b) Addition of petroleum coke and breeze to blend, c) Preheating of coal charge, d) Method of charging, d) Rank of coal and e) Charge bulk density. The main influence lies in adding proportions of low volatile coal or petroleum coke in the oven charge to reduce to pore size and increase the pore wall thickness and thereby the volume porosity diminishes because of reduction in pore size of coke.

Preheating generally results in reduction in the volume porosity of the coke but it brings in a structure with a greater number of small pores with a consequent reduction in the pore wall thickness of inter-pore-spacing as compared to the coke from a normal process.

When considering the influence of the rank of blend carbonized on the coke porous structure, it is found for coal blends typical of those used commercially, that increasing the blend rank as measured by the percentage of Vitrinite reflectance (MMR), decrease the volume porosity and pore size with no systematic effect on the pore wall thickness and a possible increase in the number of pores. Where, increase in dry bulk density results in a reduction in volume porosity and reduction in pore size.

#### *Error in sampling and analysis*

Coke after quenching is segregated in different size fractions, which depend on the market demand of the Foundry coke and Blast furnace grade coke. The various fractions segregated out from runoff oven coke are as follows:

*Gross coke:* It is the material running out of the oven and is taken out without any screening operation. The runoff coke from the oven is quenched and dumped in adjacent coke hopper which is instantly transferred on to the conveyor by a vibrating feeder. For sampling of gross coke, the belt conveyor is stopped and coke from a portion of 1mt. length is collected in tin and sent to the laboratory for moisture analysis.

*Foundry grade:* The gross coke is screened over 70mm screen cloth at Screen1. The quantity generated is around 25 to 30% of the gross coke. The >70mm material coming out is bulky and has hot patches at its centre. This coke is again passed over a conveyor having overhead water spraying arrangement. Later this coke is collected in foundry coke hopper and then transferred to coke storage yard by trucks. Random sampling method is adopted of each unloaded truck heap. The sample is collected in the tin and is sent to laboratory for moisture testing.

*Blast furnace grade coke:* The requirement of mini blast furnace of integrated steel plant is 20-70 mm. The gross coke after removing foundry grade coke is screened over same sized mats and BF grade coke is separated out in specified hoppers. Sometimes the material is passed on through coke cutter to give uniformity and strength to the coke. The BF coke so generated is about 65 to 70% of gross coke. The coke is immediately transferred by trucks after weighment to discharge point at Pig Iron Plant (PIP). At PIP, the coke is unloaded into the coke hopper and is transferred via belt conveyor to coke shed. The BF coke samples are drawn at regular frequency by stopping the conveyor and drawing out coke from a portion of 1mt. length. The sample is collected in tins and sent to laboratory for moisture testing.



**Nut coke and Coke breeze:** The coke is further screened to take out coke fractions of sizes 10-25, 6-15 and < 6mm over various screen mats. The quantity so generated is around 2, 3 and 6% of gross coke respectively. These products are taken in respective

hoppers. The coke is then transferred to the coke yard by trucks. The moisture sample is drawn from heap of each unloaded truck by piercing a standard scoop inside the heap. The sample is collected in tins and sent to laboratory for analysis.

**Analysis of Coke moisture:** The coke moisture testing in laboratory is done according to international standard ISO 579 - 1981 (E). The collected sample is reduced to 1Kg and is crushed to <20mm size in jaw crusher. The sample kept in a tray and is heated to a temperature of 200°C in oven until constant mass is obtained. The percentage moisture content is calculated from the loss in mass of the sample.

Online moisture analyzers [3] are also available for monitoring of coke moisture on continuous basis. The cross checking of moisture results can be done using this measurement tool. These are:

**Microwave Transmission:** The velocity of propagation of microwaves through a material is inversely proportional to the square root of the dielectric constant. This provides an effective method of measuring the moisture content of material on the conveyor belt. The microwave method of moisture measurement will not work with materials of high electrical conductivity such as coke.

**Fast neutron and gamma ray transmission (FNGT):** This technique relies on the large fast neutrons scattering cross section of hydrogen nuclei. It gives percentage of hydrogen by weight per unit area of measurement. Hence, indicating percentage of moisture in coke.

#### Quench water system

Following are some defects in quench water system identified which will directly or indirectly link with increasing coke moisture: Improper quench water line design, Improper layout of nozzles, Blockage in nozzles, Defective nozzles, Leakage in main channel gasket, Low flow rate of quench pumps and Deposition of sediment in main header. These faults are discussed in previous sections. Short term or long term plans are required to be formulated to address the problems.

#### Root cause analysis

Once the causes for occurrence of an event are identified and evaluated, the next step is to find out the root cause. Based on evaluation some of the root causes spotted are as follows:

1. Excess water addition due to coke remaining in hot car or in coke hopper for longer duration and through dust suppression system is the major root cause. Proper maintenance of spray nozzles of dry fog system and eliminating cause of failure of coke movement can get rid of this problem.
2. Fault in the quench valves, nozzles, seals leading to dripping of water on coke bed is the next cause. This

can be avoided by preventive maintenance or replacement of these parts.

3. The improper gap in hot car liners is major concern. The gaps are to be set at as per design. Any blocking during the regular operation needs to be removed for better performance.
4. Use of High VM coals in coal blend increases porosity in coke. By restricting VM to its limit this problem can be eliminated.
5. Human error in drawing of samples and subsequent analysis is a point to be considered. Monitoring of coke moisture using online moisture analyzer is the best option. With this immediate corrective action is possible.
6. The re-circulated water for quenching operation takes sediments causing damage to valve seats, choking of nozzles / pipeline header etc. Regular cleaning and maintenance of quench water system is the prime requisite to solve the problem.

#### Standard operating procedure

Initial checks:

- a) Ensure that all the nozzles operate at its full capacity covering entire hot car tray.
- b) Quench valve in good operating condition, without leakage/ dripping, quench stroke should be as specified. Front and back end of hot car tray have minimum gap during alignment.
- c) Suitable gaps are maintained in hot car tray, large enough for draining of water in minimum time after quenching (45seconds) at the same time small enough to allow flooding /submerging of coke.

For Quenching Operation:

- a) The uniform quenching of coke can be achieved by keeping hot coke submerged in water during entire quenching cycle. This can be achieved by having long quenching stroke initially and later on staggered stroke to maintain the water level.
- b) Total quench time should be generally between 90 to 120 sec. depending upon coke initial temperature and coke final temperature after quenching. The later should be around 200°C at exit of coke hopper.
- c) After quenching, water from quench car tray must be fully drained preferably within 45 seconds. Then the coke must be immediately put in coke hopper and

Fig.6. Bar chart showing comparison of moisture variation

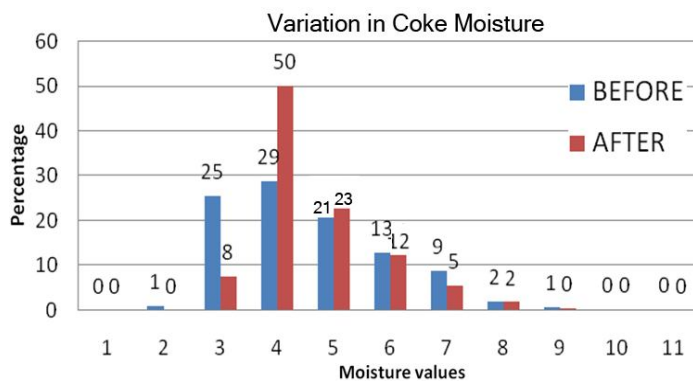
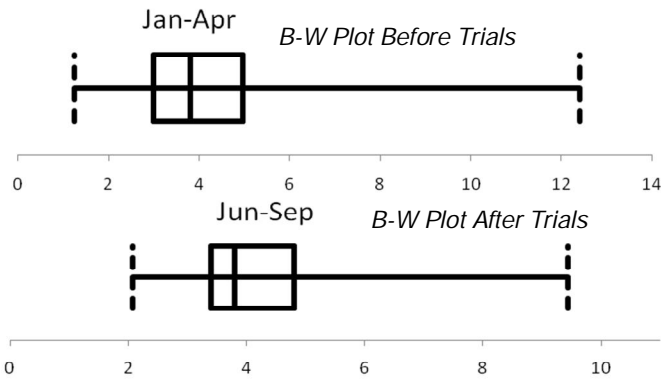



Fig. 7. Box-and -Whisker Plot



passed on the conveyor for allowing it to drying and evaporate the moisture.

**Results validation**

This exercise is carried out at Metallurgical coke manufacturing unit named "X" (name is kept confidential) with capacity of 6.0MT of coke PA. Sufficient data was available for judging the variations in moisture level before and after the corrective actions was initiated. The data was analyzed using statistical tools such as A) Bar chart, B) Box and whisker plot, C) Levene's test for equal variance and D) Standard deviation for the data of a quarter before and after the corrective measures.

**Bar chart**

In a Bar chart, a bar shows each category, the length of which represents the amount, frequency, or percentage of values falling into the category. Bar chart allows comparing percentages of each category. Fig. 6 compares the variation of coke moisture for each moisture value before and after the corrective action. It

indicates that after corrective action 73% of moisture values are in the range of 4 to 5% in comparison with 50% in earlier case. The scatter of the moisture values has considerably reduced and is clearly seen in the chart. *The Box-and -Whisker Plot*

A box-and whisker plot provides a graphical representation of the data based on a five number summary. Fig.7 illustrates the box-and whisker plot for the values of moisture before and after the trials. The vertical line drawn within the box represents the median. The vertical line at the left side of the box represents the location of Q1, and the vertical line at the right of the box represents the location of Q3. The median return and quartile of before trial is slightly higher than after trial. In both the cases right-skewed due to the long upper whisker.

The result shows that the span of readings before trial is much larger with low cluster around median, whereas more uniformity is found in the readings after trial.

*Levene's test for homogeneity of variance*

Although the one-way ANOVA *F* test is relatively robust with respect to the assumption of equal group variances, large differences in the group variances can seriously affect the level of significance and the power of the *F* test. One procedure with high statistical power is the Levene's Test. In Fig.8 significant difference in variation is found in before trial than after trial results. The test was carried out by using Minitab 14.

**Standard deviation**

Standard deviation is mostly used as a measure of variance. Unlike the sample variance, which is a squared quantity, the standard deviation is always a number that is in the same units as the original sample data. The

Fig.8. *F* test and Levene's Test

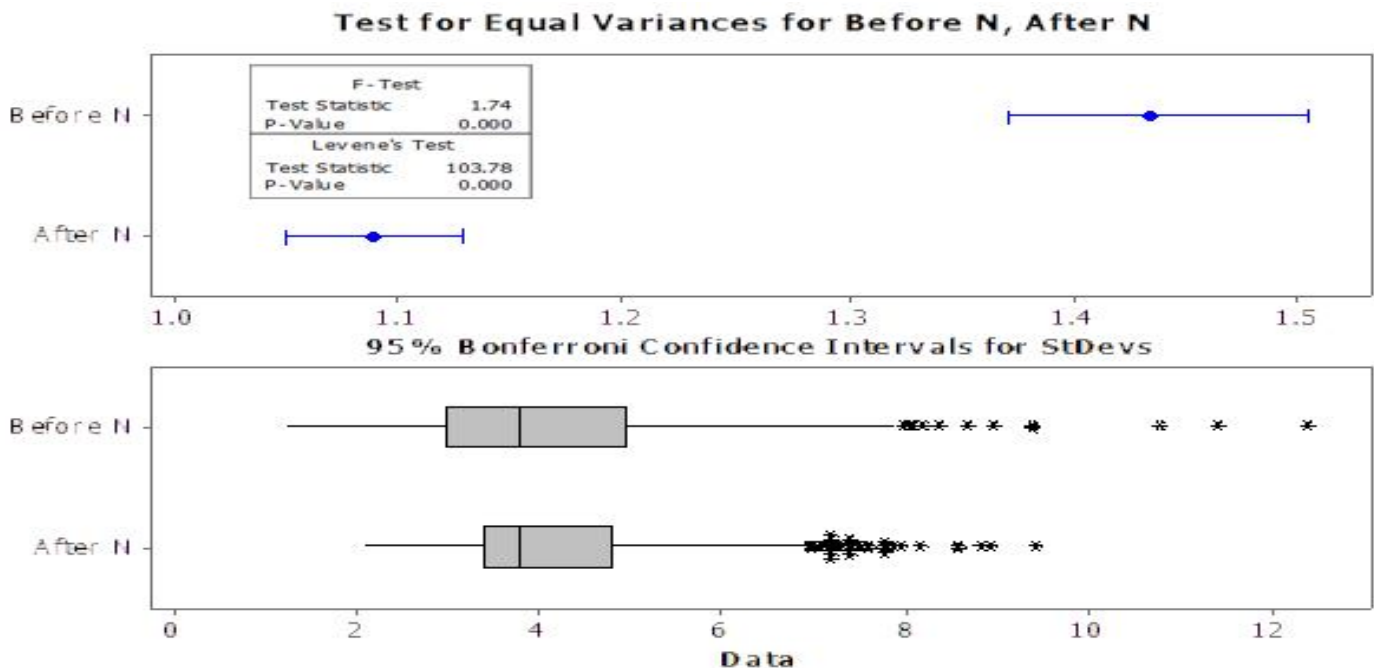

Chart 1. Daily standard deviation used for brainstorming exercise

| Date | Sep-08 | Dec-08 | Mar-09 | Jun-09 | Sep-09 | Dec-09 | Mar-10 | Apr-10 | May-10 | Jun-10 | Jul-10 | Aug-10 | Sep-10 |
|------|--------|--------|--------|--------|--------|--------|--------|--------|--------|--------|--------|--------|--------|
| 1    | 1.7    | 1.2    | 1.1    | 0.8    | 2.2    | 0.4    | 1.2    | 0.9    | 1.0    | 0.9    | 0.8    | 1.2    | 0.9    |
| 2    | 1.9    | 1.1    | 1.5    | 1.0    | 0.6    | 1.1    | 0.4    | 1.3    | 0.7    | 1.1    | 0.4    | 1.3    | 0.9    |
| 3    | 1.0    | 0.8    | 0.7    | 1.1    | 2.9    | 1.0    | 1.2    | 1.6    | 1.7    | 1.1    | 0.4    | 1.2    | 1.3    |
| 4    | 1.8    | 1.0    | 1.2    | 1.2    | 0.8    | 1.0    | 2.7    | 1.5    | 1.1    | 0.8    | 1.4    | 1.0    | 1.1    |
| 5    | 2.7    | 1.2    | 1.9    | 0.9    | 1.0    | 1.3    | 1.3    | 1.8    | 1.7    | 1.0    | 0.5    | 1.2    | 1.0    |
| 6    | 2.2    | 0.5    | 1.6    | 0.6    | 1.1    | 0.8    | 1.0    | 1.6    | 0.9    | 1.0    | 0.5    | 0.7    | 1.1    |
| 7    | 1.0    | 1.0    | 1.2    | 1.1    | 0.5    | 1.2    | 1.5    | 1.9    | 0.8    | 0.7    | 0.6    | 0.8    | 0.9    |
| 8    | 1.2    | 0.9    | 2.1    | 1.0    | 2.3    | 0.9    | 1.2    | 1.2    | 1.5    | 0.7    | 0.8    | 0.9    | 0.8    |
| 9    | 0.7    | 2.5    | 1.0    | 1.1    | 1.3    | 1.3    | 1.4    | 2.2    | 1.1    | 0.7    | 1.4    | 1.2    | 1.3    |
| 10   | 0.8    | 1.4    | 1.1    | 0.4    | 1.2    | 1.7    | 1.6    | 1.0    | 1.5    | 1.0    | 1.2    | 1.0    | 1.1    |
| 11   | 1.2    | 0.5    | 0.9    | 1.3    | 1.4    | 1.7    | 1.5    | 1.7    | 0.5    | 0.8    | 1.4    | 1.0    | 1.1    |
| 12   | 1.2    | 2.8    | 1.2    | 0.9    | 1.8    | 1.6    | 1.0    | 1.6    | 1.2    | 0.6    | 1.1    | 1.0    | 1.3    |
| 13   | 1.2    | 2.3    | 0.3    | 0.5    | 1.7    | 1.3    | 1.6    | 1.2    | 1.2    | 1.2    | 0.9    | 1.1    | 0.8    |
| 14   | 1.8    | 2.3    | 1.7    | 1.2    | 1.8    | 1.3    | 1.6    | 1.4    | 0.7    | 1.1    | 1.3    | 1.3    | 0.9    |
| 15   | 0.2    | 0.5    | 1.7    | 0.8    | 1.7    | 1.4    | 1.4    | 1.8    | 0.9    | 1.1    | 1.2    | 0.7    | 0.9    |
| 16   | 1.2    | 1.4    | 1.9    | 0.9    | 0.9    | 0.5    | 0.9    | 2.7    | 0.7    | 1.6    | 1.0    | 1.3    | 1.4    |
| 17   | 0.8    | 1.9    | 1.0    | 1.0    | 1.6    | 0.7    | 1.1    | 1.6    | 0.9    | 1.0    | 1.6    | 1.2    | 1.3    |
| 18   | 1.5    | 1.5    | 0.7    | 1.7    | 0.7    | 0.9    | 1.6    | 1.2    | 0.7    | 1.0    | 0.4    | 0.7    | 0.9    |
| 19   | 0.7    | 1.8    | 0.8    | 0.9    | 1.2    | 0.7    | 0.9    | 1.4    | 0.6    | 0.7    | 1.0    | 1.3    | 1.0    |
| 20   | 1.6    | 0.8    | 1.3    | 0.8    | 1.5    | 1.5    | 1.4    | 1.1    | 1.1    | 0.9    | 1.3    | 1.2    | 0.6    |
| 21   | 2.0    | 0.8    | 0.8    | 0.6    | 1.4    | 0.8    | 1.2    | 0.8    | 0.6    | 0.9    | 1.2    | 1.8    | 1.1    |
| 22   | 0.6    | 0.9    | 2.0    | 1.0    | 1.3    | 1.1    | 1.1    | 0.7    | 0.5    | 0.5    | 1.2    | 1.5    | 0.8    |
| 23   | 1.5    | 1.3    | 0.9    | 1.2    | 0.9    | 1.5    | 1.2    | 1.1    | 1.3    | 0.9    | 0.9    | 1.2    | 0.8    |
| 24   | 0.9    | 1.6    | 1.1    | 0.7    | 1.3    | 1.2    | 1.7    | 0.9    | 1.1    | 0.4    | 1.4    | 1.1    | 1.6    |
| 25   | 1.2    | 1.5    | 0.8    | 1.1    | 0.9    | 1.6    | 1.5    | 1.5    | 0.8    | 1.3    | 1.2    | 0.5    | 0.9    |
| 26   | 1.1    | 1.1    | 1.0    | 1.0    | 1.2    | 0.8    | 1.4    | 1.1    | 1.1    | 0.7    | 1.2    | 1.1    | 1.0    |
| 27   | 1.4    | 1.2    | 1.8    | 1.4    | 0.8    | 1.4    | 1.4    | 2.3    | 0.8    | 0.7    | 1.3    | 1.2    | 0.7    |
| 28   | 1.3    | 1.6    | 0.9    | 1.8    | 1.0    | 1.1    | 1.3    | 1.8    | 0.5    | 0.6    | 1.3    | 0.8    | 1.1    |
| 29   | 1.3    | 0.5    | 2.2    | 1.1    | 1.7    |        | 1.0    | 1.4    | 0.8    | 0.7    | 1.3    | 0.9    | 1.1    |
| 30   | 1.9    | 1.8    | 1.0    | 3.0    | 0.9    |        | 1.3    | 1.2    | 0.6    | 0.9    | 1.1    | 1.1    | 1.1    |
| 31   | 1.4    |        |        | 2.7    | 0.7    |        | 1.2    |        | 0.6    |        | 1.0    | 0.9    |        |

standard deviation helps to know how a set of data clusters of distributes around the mean. For almost all sets of data, the majority of the observed values lie within an interval of plus and minus one standard deviation above and below the mean. Therefore, knowledge of the mean and standard deviation usually helps to define whether at least the majority of the data values are clustering.

Mean of moisture readings before & after trial are 4.12 & 4.21 and standard deviations for the same are 1.43 and 1.09 respectively. Higher standard deviation

Fig. 9. Standard deviation of coke moisture

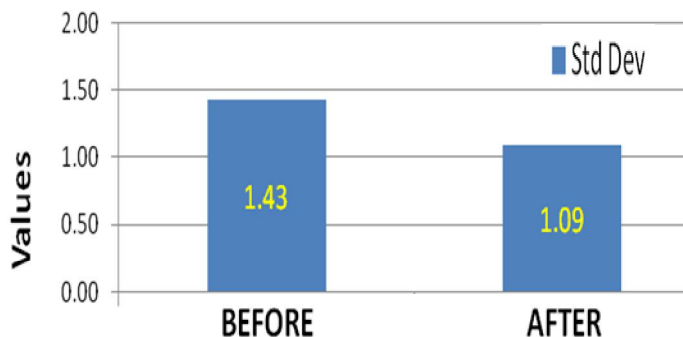

means lesser is the cluster around mean which is seen in case of readings before trial (Fig.9)(Chart 1) .

**Conclusion**

The coke to hot metal proportion changes due to the variation in coke moisture has a large impact on operation of Blast furnace. In a 'Just in time' system, where there is no scope for drying of material, the control of moisture is a big challenge for the coke manufactures. If the coke moisture is less then coke temperature at wharf will be high causing the down stream belt to burn. On other hand high moisture in coke will subject to penalty by the Pig iron customer. The exercise of identifying potential factors causing variation in moisture and formulating Standard Operating Procedure based on root cause analysis seems to be an successful effort as deviation has reduced from 2.5% to 1.0% in a quarter.

**References**

1. Walker Sr DN and Barkdoll MP (2003) Sun Coke Company's heat recovery cokemaking technology. High coke quality and low environmental impact. *Rev. Met. Paris.* 100 (3), 233-241.
2. World Bank Group (1998) Pollution Prevention and Abatement Handbook. pp:286-290.